



UK Version



Revision: 1.2
Year: 2022

BS:EN 1756-2-2004 and
A1:2009

Instruction Manual

Mega Coach Lift

MEG-1650, MEG-1850, MEG-2050, MEG-2170

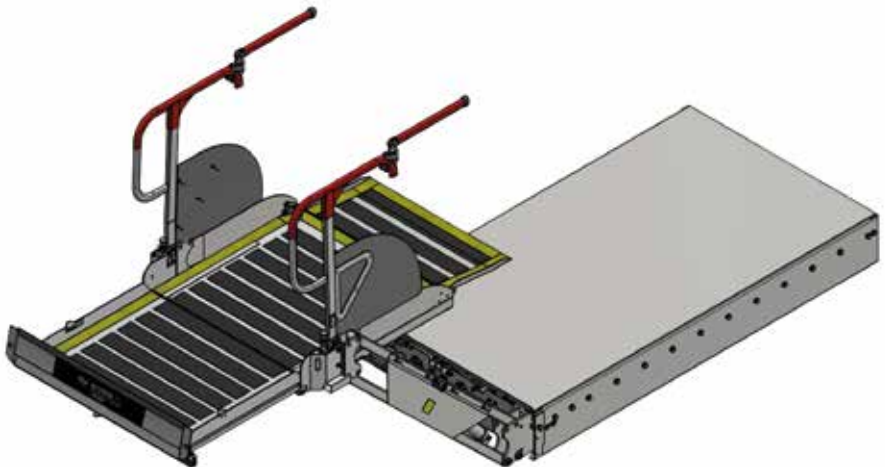

Mega Coach Lift

www.passengerliftsolutions.co.uk



1. GENERAL

- 1.1. Manufacturer
- 1.2. Markings
- 1.3. Using the Manual (symbols etc)
- 1.4. Operator Responsibility
- 1.5. Health & Safety for Scooters and Large Powered Wheelchairs

2. TECHNICAL

- 2.1. Main Components Mega
- 2.2. Dimensions Mega
- 2.3. Technical Data (Volts, PLS Blue)

3. PRODUCT USE:

- 3.1. Intended Use
- 3.2. Improper Use

4. SAFETY DEVICES

- 4.1. Description of Safety Devices

5. STICKERS

- 5.1. Description of Labels & Stickers

6. LOGISTICS

- 6.1. Receipt and Inspection
- 6.2. Storing the Lift
- 6.3. Handling

7. INSTALLATION

- 7.1. Risk Assessment (Example only)
- 7.2. General Installation- Lift mounted in Bottom Locker
- 7.3. General Installation- Lift mounted in Middle Locker
- 7.4. Power Pack Mounting Options
- 7.5. Slim line Power Pack Mounting Options
- 7.6. Checking the Power Pack Oil Level
- 7.7. Hydraulic and Electrical Fittings
- 7.8. Floor Height Adjustment
- 7.9. Bridge Plate Adjustment
- 7.10. Switch Bracket Adjustment
- 7.11. Weight Test- Dynamic
- 7.12. Weight Test- Overload, Drift & Static
- 7.13. Installation Checklist
- 7.14. Torque Settings

8. OPERATION

- 8.1. Standard Operation procedure
- 8.2. Manual Override

9. CLEANING

- 9.1. Cleaning Instructions

10. SERVICE AND MAINTENANCE

- 10.1. UK Service & Warranty
- 10.2. Loler
- 10.3. Daily Inspections
- 10.4 Weekly Inspections
- 10.5. Monthly Inspections
- 10.6. Six Monthly inspections
- 10.7. Lubrication
- 10.8. Point Check

11. DISPOSAL

- 11.1. Safe Disposal

12. TROUBLE SHOOTING

- 12.1. Trouble Shooting

13. DIAGRAMS

- 13.1. Wiring Diagram- Power Pack
- 13.2. Wiring Diagram- Lift
- 13.3. Hydraulic Diagram

14. SPARE PARTS

- 14.1. Contents List of Spare Parts Mega
- 14.2. Spare parts request form Mega

15. NOTES



General

1

1.1 Manufacture Mega



Passenger Lift Solutions Limited

Unit 2, Summit Crescent Ind. Est.,
Smethwick,
West Midlands
B66 1BT. U.K.
Tel: +44 (0)121 552 0660

1.2 Manufacture Mega

The lift device is manufactured in compliance with the relevant EC directives applicable on the date of entering the market. Considered a “medical device” pursuant to article 2, point 1), letter a), first paragraph of directive 2007/47/EC, the device carries a specific identification plate which, in addition to the specific technical data also includes the CE marking, guarantee of the compliance of the device to the directives/ standards referred to the enclosed Declaration of Conformity.

The plate, a facsimile of which is shown here, is printed with the data indicating the specific model and unit.

NOTE: The Lift Serial number will be required for ALL correspondence with factory



CUSTOMER NAME:	_____
INSTALLER NAME:	_____
DATE OF INSTALLATION:	_____
SERIAL NUMBER:	_____

IT IS PROHIBITED TO REMOVE OR TAMPER WITH THE IDENTIFICATION PLATE

1.3 Using the Manual Mega

This manual aims to provide users and operators with all the information they require to ensure that they are able both to use the lift appropriately and are able to manage it as autonomously and safely as possible.

Before performing any operations on the lift, users and operators must carefully read the instructions given in this publication.

In the event of doubt over the correct interpretation of the instructions, contact the PLS technical department to obtain the required clarifications.

This manual is an integral part of the lift, it must be kept safely by the purchaser and made available for use by the operators.

The contents of this manual comply with the Directive 2007/47/EC and were drafted following the guidelines given in UNI 10893:2000. They also comply with the requirements of UNI EN ISO 10535:2007 and BS EN 1789:2007 and A2:2014

Data and drawings are indicative only; with a view to the continuous development and updating of its products, the manufacturer may modify the contents without notice.

It is prohibited to disclose, edit or use this manual for any other purposes.



This symbol indicates **IMPORTANT** Information used by the Manufacturer and the User.



This symbol indicates areas that need routine maintenance.



This symbol indicates Operators areas of responsibility.



This symbol indicates **IMPORTANT** areas for the Safe operation of the Lift.



This symbol indicates that a potentially hazardous situation could occur.



This symbol indicates improper use of the lift.



1.4 Operators Responsibility Mega

The operator is individually responsible for the safe use and maintenance of the lift.

They are also responsible for the lift users and their own personal safety and in the event of an accident they will be prosecuted to the full extent of the law if they are deemed negligent.

Legal action will also be taken if any unauthorised modifications are made to the lift without direct prior written authority by a PLS director.



The lift owner is the person who purchases the product, uses or oversees the use of the lift, this person is legally responsible for the lift's safe use.



The accompanying person, also known as the operator is responsible for the safe operation of the lift.

The operator must be full trained in all the operation aspects of the lift such as the transportation of people with motor deficiencies or disabilities. The operator must exhibit the following characteristics/ attributes for them to safely operate the lift:

PHYSICAL – Possess the required physical qualities/ characteristics sufficiently to ensure safe operation of lift in a safe and controlled manner. Examples include:

- Good hearing & sight
- Physically capable of performing all operational functions of lift
- Not impaired by the consumption of legal and/or illegal substances (such as alcohol and/ or drugs)

MENTAL - Possess the required mental qualities / characteristics sufficiently to ensure safe operation of lift in a safe and controlled manner. Examples include:

- Understanding & application of the safety rules and procedures while operating the lift.
- Be constantly aware and pro-active to ensure the safety of the operator, user and nearby people.
- Have the knowledge/ skills to perform as an assistant and/ or operator in all aspects of lift operation. E.g. the safe transportation, loading and unloading of disabled and other passengers.

EMOTIONAL - Possess the required emotional qualities/ characteristics sufficiently to ensure safe operation of lift in a safe and controlled manner. Examples include:

- Work in a calm & safe manner while under stress so to prevent stress from impairing good judgement.
- To be emotionally stable during normal or abnormal situations

TRAINING – Possess the required training qualities sufficiently to ensure safe operation of lift in a safe and controlled manner. Examples include:

- Completed operational training supervised by an experienced operator in PLS lifts in an environment which is safe and controlled. Such supervised training should allow the trainee to gain working experience in all operation aspects of the lift.



The lift owner is responsible for distributing and ensuring that a copy of this manual is read and fully understood by all potential lift operators before operating the lift.



No operator will use the lift if they believe it is unsafe and doing so could injure themselves or others, they MUST report their concerns directly to their manager or PLS.

1.5 Health & Safety (Scooters) Mega

Safety Instructions for 'Scooters' and Large Powered Wheelchairs

Before operating tail lift:

Fully familiarize yourself with lift controls, relevant safety procedures and possible hazards, signified by warning labels or highlighted in your 'Operators Risk Assessment'.

Tail lift safety:

- Only an authorised (fully trained) operator must control the lift.
- Secure vehicle doors fully open, well clear of the lift platform.
- Keep within the stated maximum safe working load (SWL).
- Keep people away from the operating area (inside and outside of vehicle).
- Ensure that the platform is always level (horizontal, not more than 5% slope in any direction).
- NEVER leave the lift unattended at ground level if passengers are on board.
- When lift is not in use the controls should be deactivated.
- Ensure that the lift is correctly stowed after loading.

Operators ensure that:

- Lift will lower to firm, level ground.
- Scooter or powered wheelchair is not larger than lift platform in any direction.
- Tail lift is in a FULLY operational condition. Report any defects.
- Lift bridging-plate lands flat onto vehicle floor.
- Roll-off ramp is set vertically (approx. 80°), and fully operational.
- Accompany the passenger on the lift if possible, but do not overload the lift.
- You have a clear view of the lift platform before the scooter moves onto it.
- NEVER leave passengers unattended at any time.
- The passenger should not be required to operate ANY controls.

Loading & Unloading procedure:

- Explain to passenger the sequence of movements that will occur.
- Where possible the passenger should dismount scooter and board vehicle separately.
- Ensure that the lift platform and area around the lift are free from obstructions.
- Ensure that the lift platform is in the correct position before moving onto it.
- Scooter should be pushed onto the lift platform, NOT DRIVEN.
- Ensure that persons or equipment do not overhang the platform.
- Scooter breaks are applied BEFORE lift begins motion (or wheels blocked).
- All power to scooter is turned OFF.
- Operate lift platform to vehicle floor.
- Scooter is pushed off the lift platform, NOT DRIVEN.
- The scooter should be clamped to the vehicle floor using the correct equipment.
- The passenger utilises the static vehicle seats and seatbelts.

Please note: The transportation of scooters and large powered wheelchairs may require a 'NON STANDARD' tail lift size or specification. Where possible PLS can provide longer, wider platforms, higher roll-off ramps to help combat the increased hazards related to larger passenger vehicle transportation.

2.1 Main Components Mega

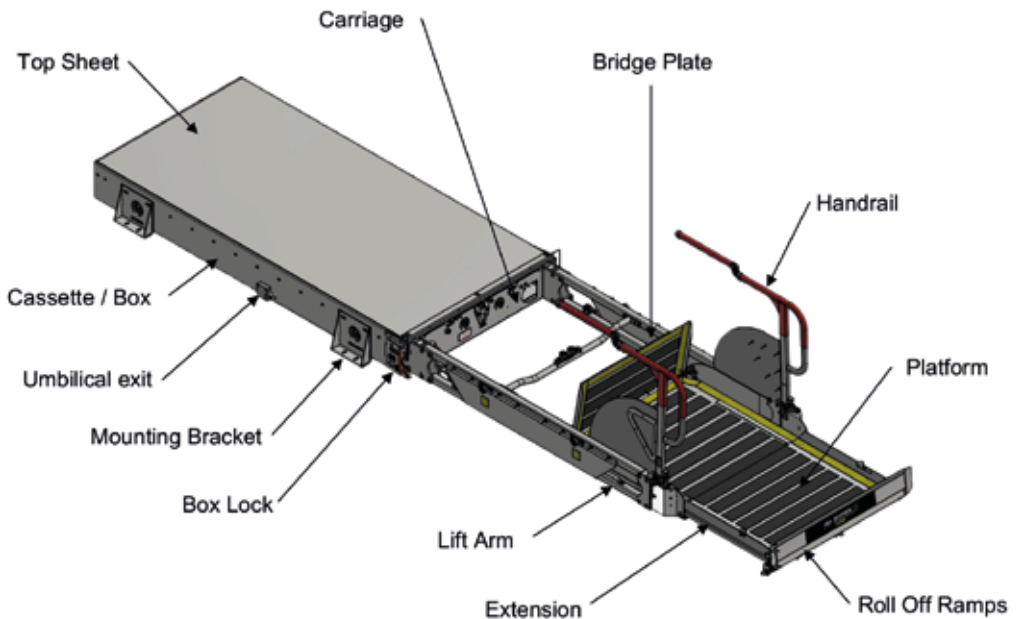
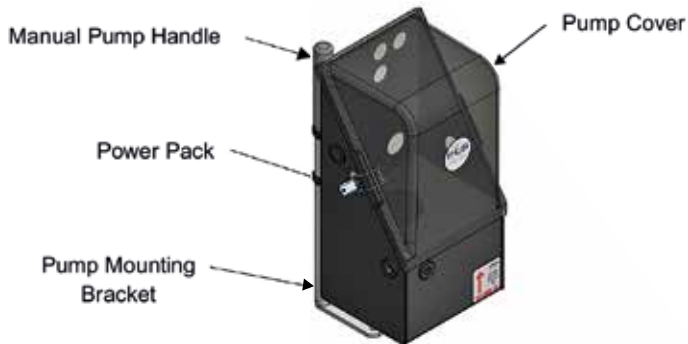

2.2 Dimensions Mega

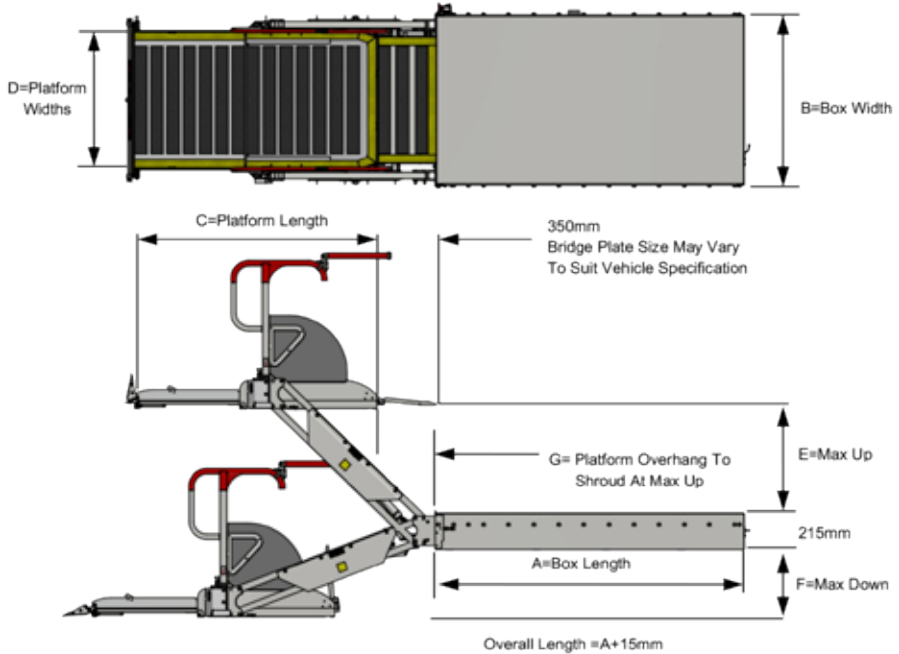

	MEG-1650 ^M	MEG-1850 ^B	MEG-2050 ^B	MEG2170 ^B
A	1650mm	1850mm	2050mm	2170mm
B	1020mm	1020mm	1020mm	1020mm
C	1410mm	1440mm	1440mm	1440mm
D	825mm	825mm	825mm	825mm
E	590mm	665mm	950mm	1150mm
F	690mm	450mm	450mm	450mm
G	250mm	300mm	250mm	200mm

Note: ^B =Bottom Locker, ^M =Middle Locker.

2.3 Technical Data Mega

The Lift is designed To Transport:



One person in a wheelchair with or without an attendant, with a size not larger than the width/ length of platform space available, or weight over the stated 'SWL' capacity

Or:



Two walking passengers. The operator should not attempt to transport more than two people at a time of increased risk of passenger discomfort. The passengers also may require extra space for mobility devices such as sticks and frames

	MEG-1650	MEG-1850	MEG-2050	MEG-2170
SWL (kg)	400	400	400	400
Voltage (DC)	24V	24V	24V	24V
Pressure (Bar)	140-150	160-170	170-180	180-190
Auxiliary Hand Pump	Yes	Yes	Yes	Yes
Lift Control	2 Button Handset	2 Button Handset	2 Button Handset	2 Button Handset

Note: Lift weight not including Power-pack & Installation Kit.
Pressure may vary depending on what compartment the Lift is fitted in.

3.1 Intended Use Mega

The lift is designed for installation on the loading floor of a vehicle designed for transportation of the disabled in wheelchairs, within the limits of the performances and capacities indicated in the technical characteristics.

The lift must only be used by an authorised and trained operator, known as the accompanying person, who possesses the knowledge and physical requirements to safely perform operations with disabled persons.

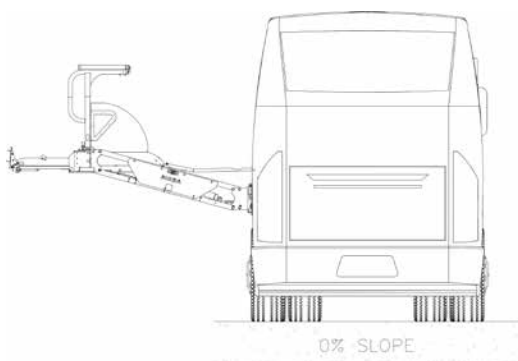
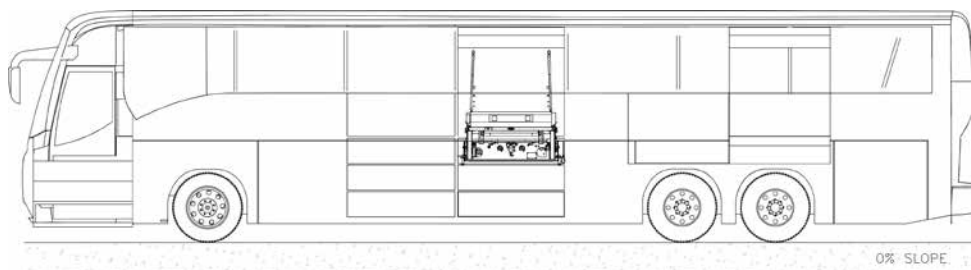

Anything that is not specifically referred to in chapter 3.1 is considered **IMPROPER USE**.



THE MANUFACTURER DECLINES ALL RESPONSIBILITY FOR DAMAGE CAUSED TO PERSONS OR PROPERTY OR TO THE LIFT ITSELF DUE TO ANY USE OTHER THAN THAT DESCRIBED IN THIS MANUAL.



3.2 Improper Use Mega

Anything that is not specifically referred to in chapter 3.1 is considered **IMPROPER USE**.



IT IS FORBIDDEN to climb onto the lift or any of its parts whilst in operation.

It is advisable to always attempt to use the lift on flat/ level ground.

The lift should not be operated if there is more than a 5.0% slope from level, in any direction. (refer to operation Risk Assessment).

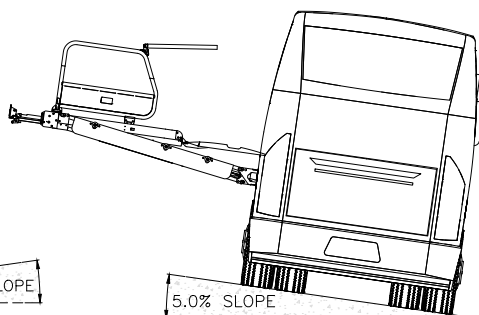
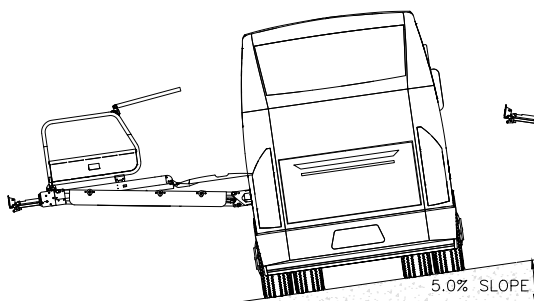
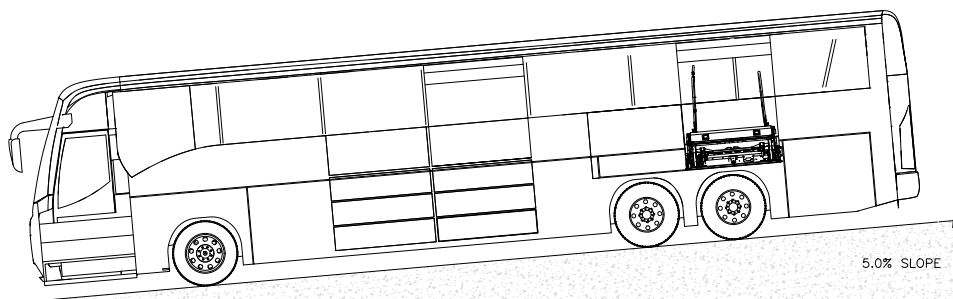

Anything that is not specifically referred to in chapter 3.1 is considered **IMPROPER USE**.



THE MANUFACTURER DECLINES ALL RESPONSIBILITY FOR DAMAGE CAUSED TO PERSONS OR PROPERTY OR TO THE LIFT ITSELF DUE TO ANY USE OTHER THAN THAT DESCRIBED IN THIS MANUAL.

4

Safety Devices



4.1 Description of Safety Devices Mega

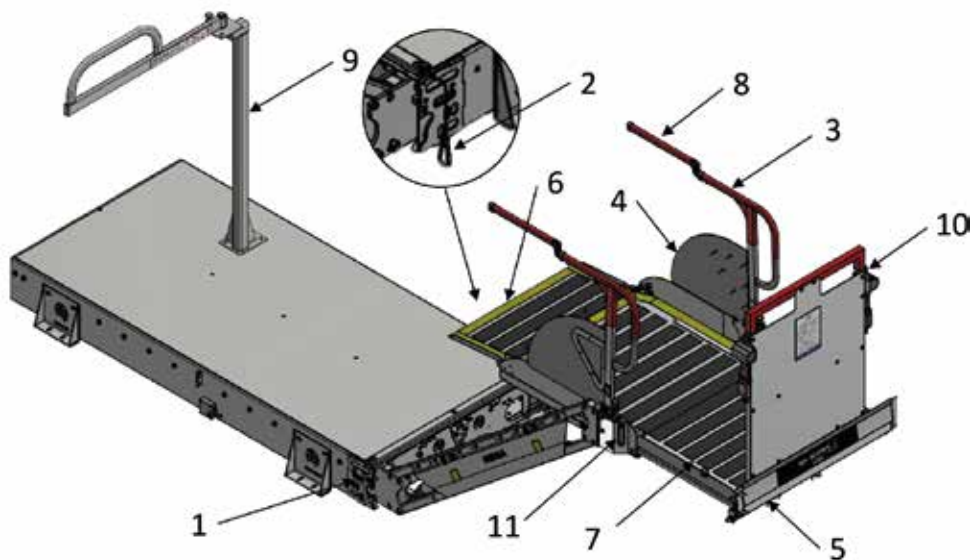

1	Box Lock (▽) Safety Critical	Standard
2	Auxiliary Safety Rope (▽) Safety Critical	Standard
3	Handrail	Standard
4	Handrail Guard	Standard
5	Roll Off Ramp (Outer Barrier)	Standard
6	Bridge Plate (Inner Barrier)	Standard
7	Anti-Slip Surface Cleatings	Standard
8	Handrail Extension	Standard
9	Universal Safety Arm	Optional
10	Stop Safe	Optional
11	"Warning" LED's	Optional



IT IS FORBIDDEN TO DISABLE, REMOVE OR TAMPER WITH THE EXISTING SAFETY SYSTEMS.



Warning Labels & Stickers

5

5.1 Description of Labels & Stickers Mega

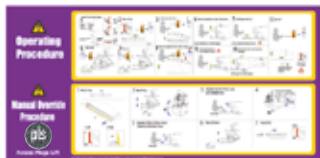

ACC28680

Access Operation Instructions Board



ACC28681

Access Safety Instructions Board



ACC 26469



PLS 321

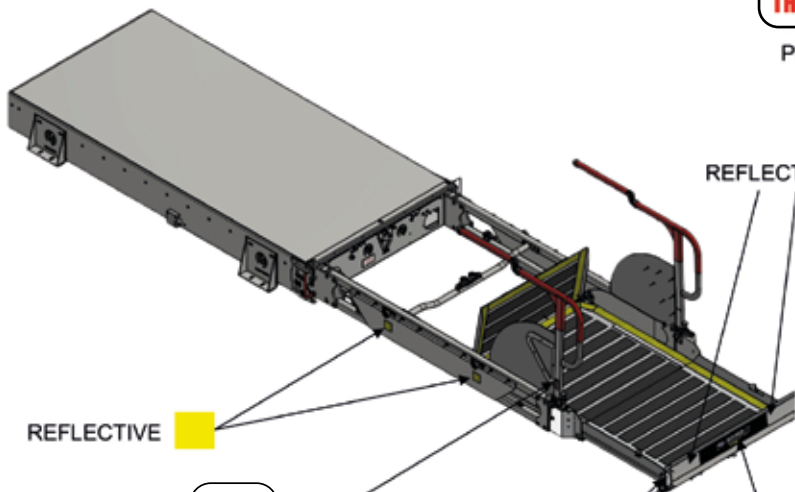

REFLECTIVE

REFLECTIVE



6.1 Receipt and Inspection Mega

Upon delivery of the lift, you need to perform the following inspections:

- Ensure the product delivered corresponds to the relevant documentation e.g. the order specification and the transport document.
- Examine packaging to ensure it is undamaged and all parts are intact during transportation.
- With great care, examine all devices to ensure they haven't been damaged during transportation and all parts haven't been tampered or removed.
- Ensure all documentation required for installation has been supplied.



IF THE DELIVERED DEVICE DOES NOT COMPLY WITH THESE REQUIREMENTS, NOTIFY THE MANUFACTURER IMMEDIATELY.

6.2 Storing the Lift Mega

If the lift is not used, proceed as follows:

- Transport lift to an appropriate storage area, free from atmospheric agents / elements.
- Ensure all electrical / electronic devices are insulated from external environment so to prevent humidity damaging those components.
- Storage area selected **MUST** ensure temperature variation is between 5°C to 50°C fresh hold.
- Ensure all sliding parts (guides, cylinders ...) are adequately protected from dust, rust and water damage.

Note: If a lift is to be dry stored for more than 12 months then all cylinder seals **MUST** be checked before operation.



STORAGE OF THE LIFT IN CONDITIONS THAT DO NOT COMPLY WITH THE ABOVE DESCRIPTION SHALL NULLIFY THE WARRANTY FOR ANY PARTS TO BE REPLACED.

6.3 Handling Mega

All lifting and short workshop distance transportation of packages lifts must be carried out using a forklift truck.

Safe lifting can only be achieved when using suitably rated load capacity equipment (Please refer to Technical Data Table for indicated lift weight)



HANDLING STAFF MUST WEAR: SAFETY SHOES WITH STEEL TOE CAP AND NON-SLIP SOLES.



MAKE SURE THAT NO UNAUTHORISED PERSONS ARE STANDING WITHIN THE RADIUS OF ACTION OF THE LIFTING/HANDLING MEANS (FORK LIFT TRUCK, TRANSPALLET, ETC.) DURING THE LIFTING, TRANSPORT AND HANDLING OPERATIONS.

Procedures for packaging removal are explained below:

- Using a Stanley Knife with a maximum blade length of 10mm, cut along the 4 sides of the base of the packaging, remove tape and ensure waste cardboard is recycled
- For wooden crates, remove nails from top panel and those present on the side walls.



STAFF REMOVING THE PACKAGING MUST WEAR: SAFETY SHOES WITH STEEL TOE CAP AND NON-SLIP SOLES, GLOVES AND SAFETY GLASSES.

7.1 General Installation - Risk Assessment Mega

Location: Passenger Lift Services Ltd		Rev No:								
Operation/Activity: Lift Operation										
List below the operations, in your opinion, which involve a significant hazard, risk of injury?	Severity		Likelihood		Risk Rating					
	1	2	3	4	5	1	2	3	4	5
Stability of lift during operation	2		1		2					
Entrapment from moving parts	2		1		2					
Slips, trips and falls	3		1		3					
Operating environment	3		2		6					
Manual operation of lift	2		3		2					
Contact with hazardous substances	2		1		2					
Fire	1		1		1					
List persons at	Operators	No injury just minor damage to plant, equipment or structure Minor injury – small cut or bruise Serious – medical treatment required – doctor or small injury clinic Major – attendance at hospital accident and emergency department Fatalities	Rare - may occur only in exceptional circumstances. (0-20% chance) Moderate - could occur at sometime. (41-60% chance) Likely - not surprised could occur several times. (61-80% chance) Certain - to be expected, will occur repeatedly. (81-100% chance)		18 Overall risk rating					
Risk rating has been defined taking into account the following control measures										
Control measures include (engineering quality control, specialist equipment information / instruction, Customer responsibilities maintained.										
Action Plan / Controls:- All lifts are supplied with safety instructions and safe operating procedures with visual instruction for the automatic and manual operation of lifts. Safety instruction is also generated and supplied for the use of lifts by scooters and large powered wheelchairs. Supply and fitted lifts have a weight test certificate and an installation and examination report completed by a competent engineer complying to; Lifting Operations and Lifting Equipment Regulations 1998. Additional controls are to be implemented and maintained by the end user, with six monthly inspections carried out on all lifting equipment conforming to; Lifting Operations and Lifting Equipment Regulations 1998.										
Has the overall risk rating been reduced to Low?		Controls are deemed adequate- proceed with the operation/activity			1-7					
Has the overall risk rating been reduced to Medium?	X	Consider additional controls, strict monitoring of controls required - proceed with caution			8-20					
Has the overall risk rating remained High?		Operation / activity is NOT to be undertaken until additional controls have been implemented - contact safety officer			21-30					
Can the risk be reduced to low by introducing additional preventative and/or protective measures? No See Risk Assessment Action Plan for additional precautions / controls to be implemented.										

Assessment carried out by:

Position:

Date:

REMEMBER: REVIEW THE ASSESSMENT IF THE CIRCUMSTANCES CHANGE SIGNIFICANTLY



Installation

7

7.2 General Installation - Lift mounted in Bottom Locker

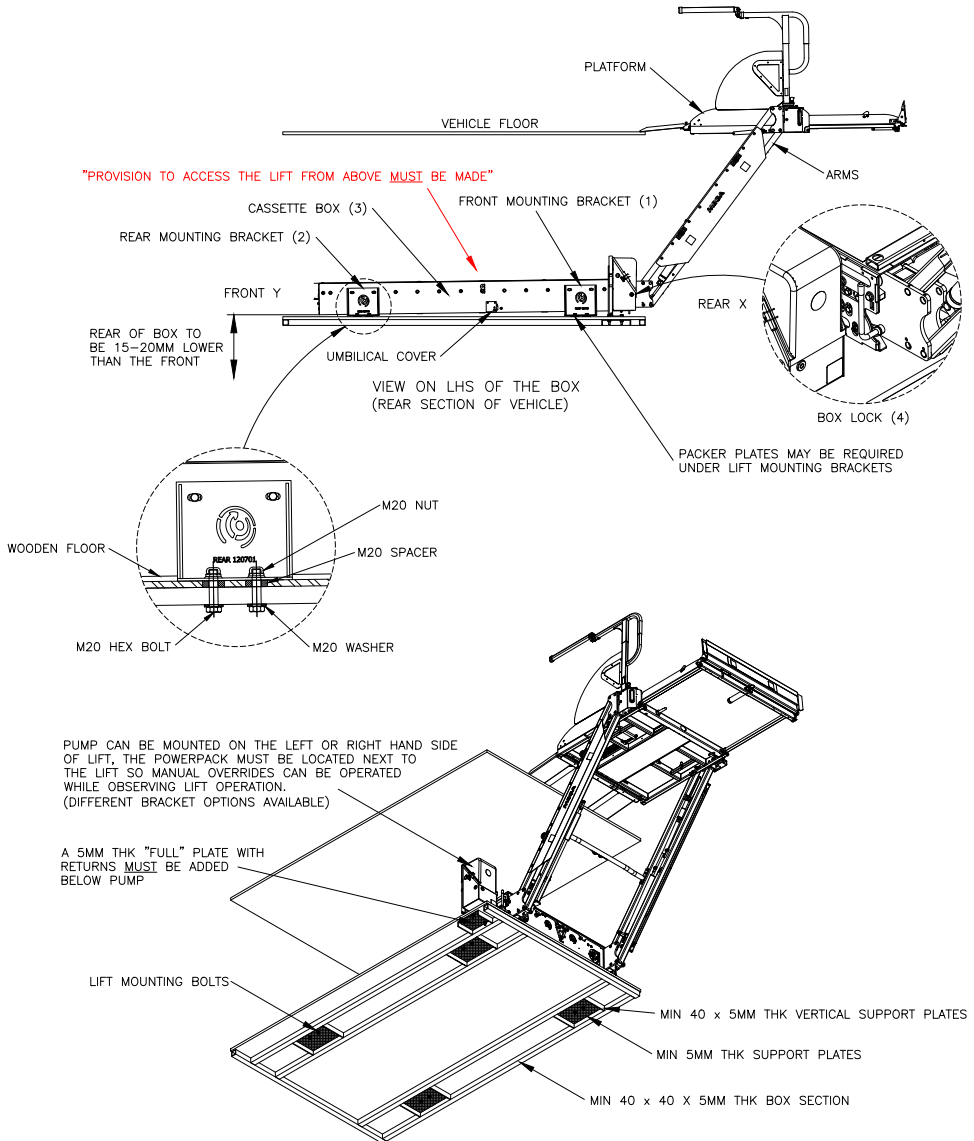

"ENSURE THAT FITTING STRUCTURE IS ABLE TO SUPPORT THE COMBINED WEIGHT OF THE LIFT AND PASSENGERS"

7

Installation

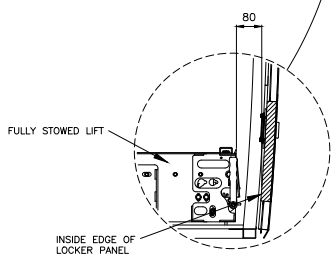
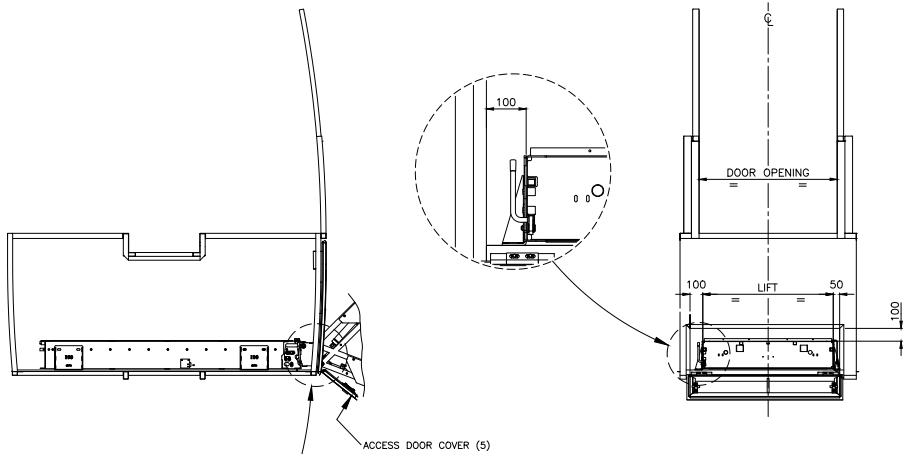
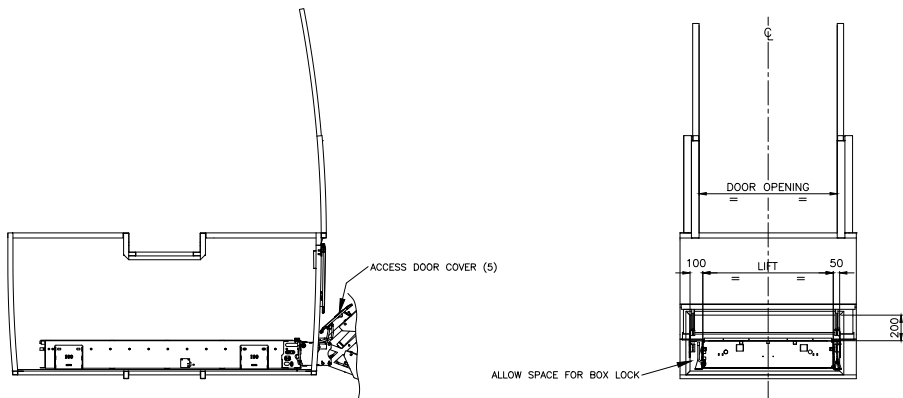

INITIAL "SET" UP POSITION OF LIFT
(DOOR COVER WITH "LOWER" HINGED COVER ILLUSTRATED)

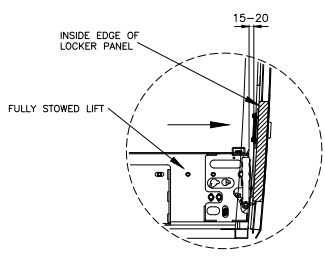

FINAL POSITION OF LIFT
(DOOR COVER WITH "LOWER" HINGED COVER ILLUSTRATED)



Installation

7

7.3 General Installation - Lift mounted in Middle Locker

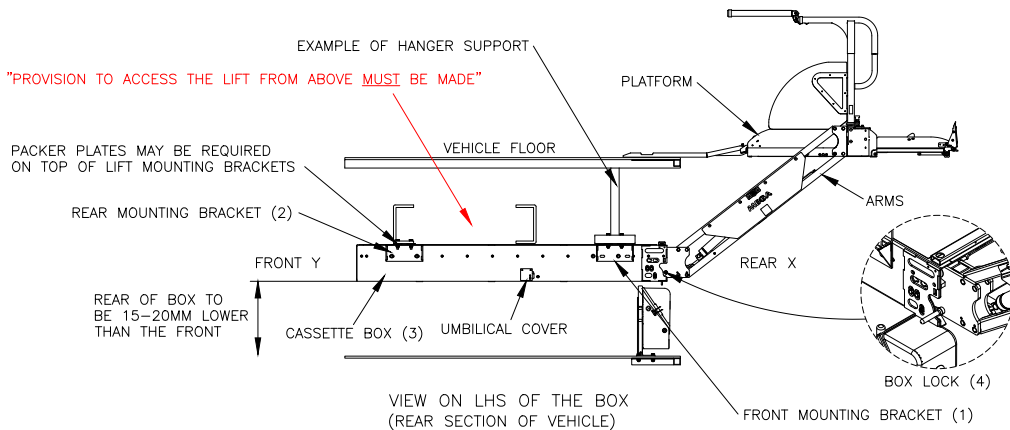

PUMP CAN BE MOUNTED ON THE LEFT OR RIGHT HAND SIDE OF LIFT, THE POWERPACK MUST BE LOCATED NEXT TO THE LIFT SO MANUAL OVERRIDES CAN BE OPERATED WHILE OBSERVING LIFT OPERATION. (DIFFERENT BRACKET OPTIONS AVAILABLE)

A 5MM THK "FULL" PLATE WITH RETURN/S MUST BE ADDED BELOW PUMP

LIFT MOUNTING BOLTS

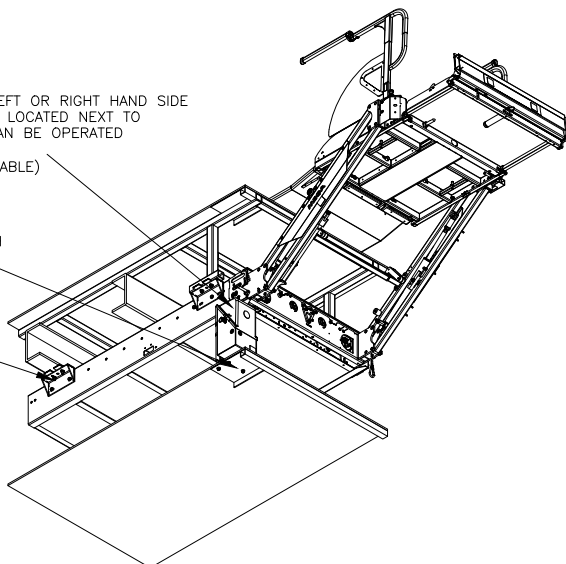

"ENSURE THAT FITTING STRUCTURE IS ABLE TO SUPPORT THE COMBINED WEIGHT OF THE LIFT AND PASSENGERS"

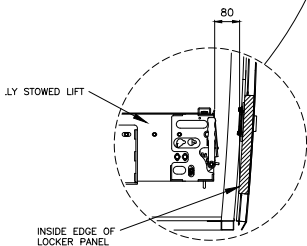
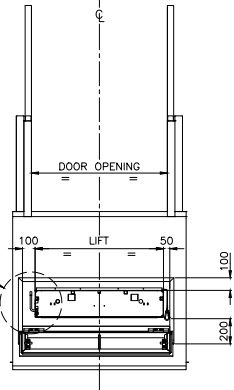
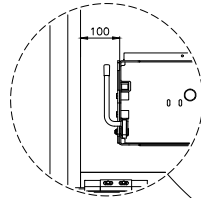
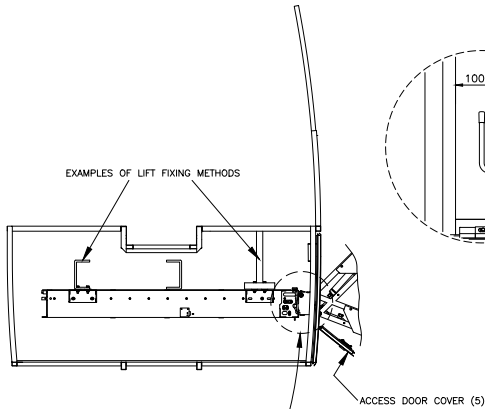
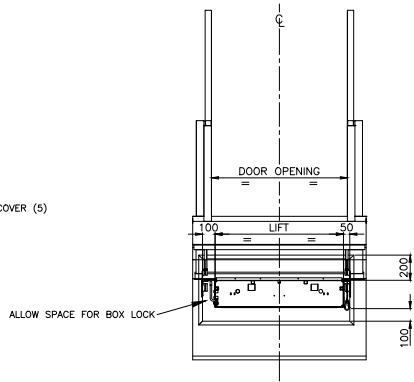
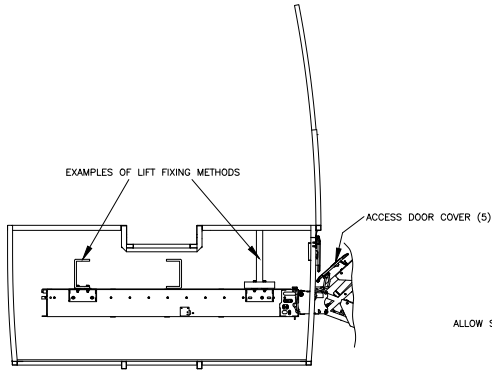

INITIAL "SET" UP POSITION OF LIFT
(DOOR COVER WITH "LOWER" HINGED COVER ILLUSTRATED)

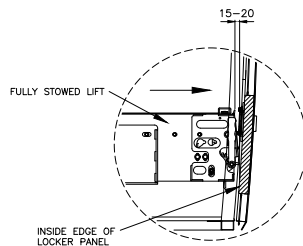

FINAL POSITION OF LIFT
(DOOR COVER WITH "LOWER" HINGED COVER ILLUSTRATED)



Fitting Instructions Generic Coach

- Cut around 4m of battery cable and conduit then feed the battery cable into the conduit; make sure that the end of the battery cable is visible out of conduit. (This length may vary due to the placement of the powerpack)

For fitting the brackets:

'Front' is taken as passenger's side; 'Rear' is taken as driver's side.



For the brackets you will need:

11x M10x40 Hex head set screws,

11x M10 Plain form A washers,

11x M10 Nyloc nuts.

- Unscrew the 4th and 5th track bolts (from the front of the lift) for the '210' brackets as well as the 2nd and 3rd bolts from the back of the box for the '190' brackets.



FRONT

REAR

- Using a crowbar, prop the lift up slightly and slide a screwdriver underneath to keep it propped up in order to attach the mounting brackets (25mm track bolts will need to be used). Repeat this process for the other three brackets.

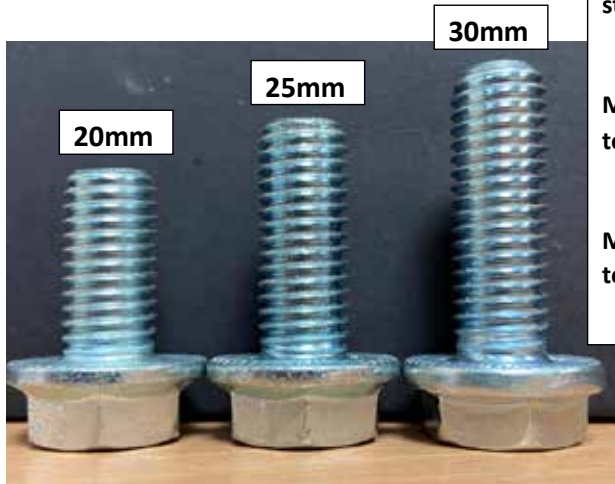
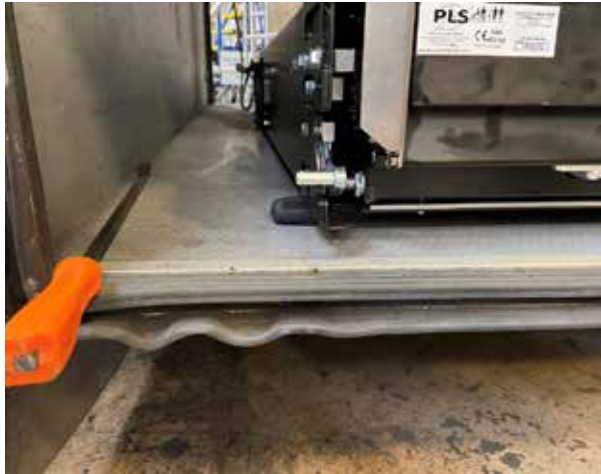

M10x20mm bolt is used as standard to hold tracks in.

M10x25mm bolts are used to hold brackets up to 6mm.

M10x30mm bolts are used to hold brackets up to 8mm.

- To make sure the lift is in the correct position close the locker door and open the lift cover to expose the lift. The correct distance from the bottom front edge of the box to the inside of the door should be around 25-30mm. The lift should be pushed up as close to the wall as possible whilst still being able to pass through the letterbox door unobstructed.



- Drill 10mm holes through the wooden locker floor in the centre of the bracket's slots, then drill a 4mm pilot hole into the steel box section fitted to the bottom of the chassis followed by enlarging the pilot hole to 10mm. **(Note: When drilling the holes for the brackets closest to the wall, longer drill bits will be needed; drill bits used in this fit were 300mm)**

NOTE: 40/50 x 5mm box section and 5mm plate is fitted to the underneath of the coach for strengthening purposes.

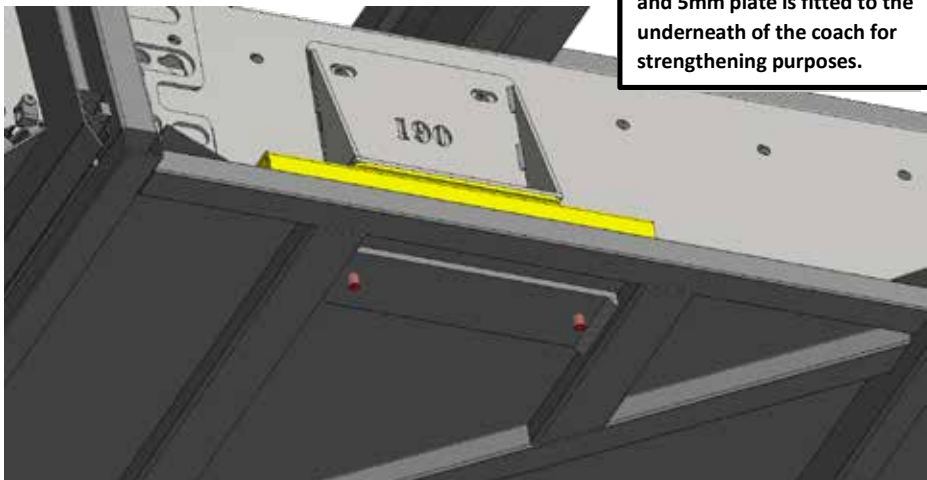

- To secure the brackets to the floor, M10x40 hex head bolts with a plain form A washer are slotted through the 10mm holes and secured on the underside with an M10 nyloc nut tightened with a 17mm spanner and 17mm torque fitting. **(Note: One of the bolts in the front right-hand bracket needs to be put through upside down for earthing, as seen below.)**



- If the lift is not level or if it is too low, then 5mm packers may need to be added underneath the front brackets, depending on how many are added, the size of the bolts will need to be increased to suit.



- The pump bracket should be roughly 20mm away from the edge of the lift bracket, with the two vertical holes furthest away from the lift as shown below.



The pump location shown here is for a standard door. For an extended door, the pump will be located in the next available door.

- Once the rough position has been decided mark through the holes with a sharpie and remove the bracket. Then, drill a 6mm pilot hole, followed by a 10mm hole for the M10x40 hex head bolts and plain from A washer to slot through and be secured with an M10 Nyloc nut underneath.



- Connect the umbilical wire to the relevant socket at the rear of the pump, then feed the umbilical wire and the hose leading from the pump, as well as the battery cable, underneath the front of the lift leading out to the left-hand side. Plug the umbilical into the socket and the female QRC to the male; once everything is connected, group the umbilical cable and hose together, loosely cable tie them and place them down the side of the lift to get them out of view.



- To secure the pump to the bracket you will need 2x M10x60 bolts with a plain form A washer and a nyloc on the other side.



- Once secured, cut a cross into the two free grommets, feed the Earth cable through the bottom grommet and attach a 10mm crimp onto the end of the wire then connect it to the upturned bolt in the bracket by slotting the crimp onto the bolt followed by a plain form A washer and an M10 Nyloc.

Do not cut out rubber grommets like this as it will let more water into the pump. A cross being cut minimizes the water that can get into the wiring.

Battery Cable

Earth Cable

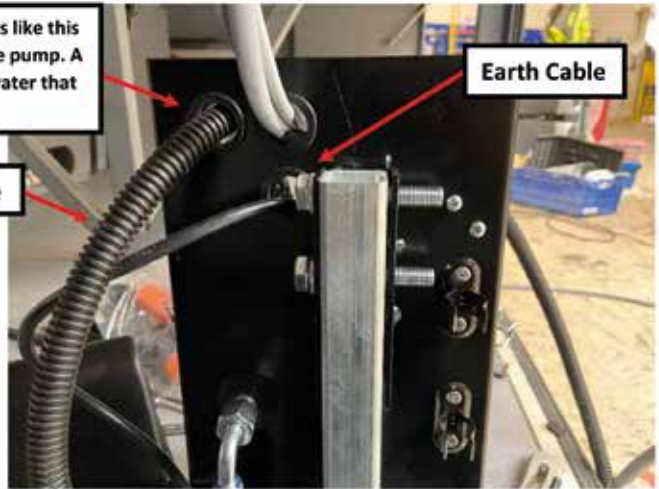

- Push the battery cable through the cross in the top grommet and attach a 6mm crimp onto the end of the battery cable leading towards the pump; cover the end of the crimp with electrical tape, tape the end of the conduit to the cable to ensure it doesn't slide and finally, slide on a rubber boot.

Rubber Boot

Battery Cable

Electrical Tape



- After doing this, secure the crimp to the pump by slotting the crimp onto the solenoid connector and then screwing on an M6 half nut; pull the rubber boot back over once connected.



- Cable tie the battery and earth cable together and then to the pump bracket to ensure they are kept out of the way and for tidiness.

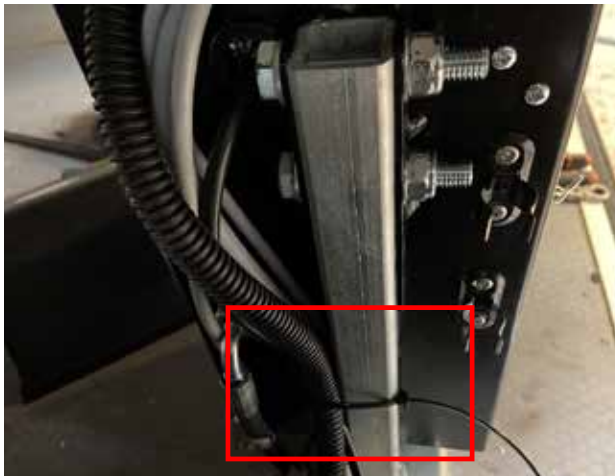

- Feed the other end of the battery cable up over the supports for the electrical box for when the circuit breaker is fitted and the battery cable is connected to the battery. Then, unclip the locks to gain access to the electrical/fuse box.

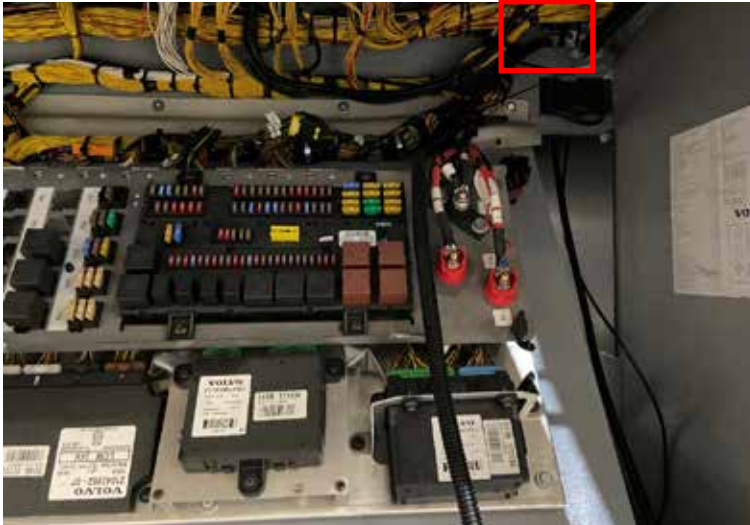

- Attach a 6mm crimp onto the end of the battery cable and cover the end of the crimp as well as the conduit to secure the cable and ensure nothing can get into the conduit; screw the crimp onto one of the terminals on the bottom of the circuit breaker.

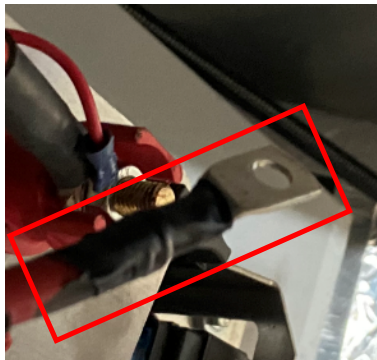

- Cut a secondary piece of battery cable to suit, attach a 6mm crimp at both ends and cover the crimped ends connecting to the cable with electrical tape; screw one of these crimps into the remaining terminal on the circuit breaker. Once both crimps are screwed in, cover the entire base of the circuit breaker in electrical tape, ensuring all metal is covered.



- Pop the cap off of the lower battery terminal so the crimp on the other end of the shorter cable can be connected.



- To connect the crimp, remove the half nut from the terminal and slide the crimp on then re-fasten the nut back onto the terminal and pop the covers back on. Then cable tie the battery cable to the already existing looms in the electrical box.



- Finally, connect the handset plug to its socket (which is fitted by Volvo).

The lift must then be weight tested. PHOTOS OF THE WEIGHT TEST MUST BE TAKEN, WHEN AT LIFT FLOOR HEIGHT.

- Lift up the box lock and power the lift out **FULLY**, pull out platform until it locks and power the lift to floor.

- After placing a piece of cardboard onto the platform, place/roll 400kg of weights onto the cardboard then power the lift up fully to floor height.



- Once completed with no faults power the lift all the way down and wheel off the weights.

- After weight test visually (or use tools if need be) check brackets and fasteners for brackets and check lift oil.

- Finally, stow the lift. After this is done, check the lift oil and top up if needed then, clip on the pump cover.

- When filling out the certificates fill out information as according and if known.

- The date of next examination is always 6 months after the installation date.

- The loler 98 regulation is the date of installation. Tick all of the 'test applied' boxes if lift has been seen to be working properly and there are no visual discrepancies. Some have actual tests that must be completed and checked off such as the creep test.

- The blue sheet is kept by the installer; the yellow sheet stays with the vehicle and the white sheet is kept by the customer.



7.4 Power Pack Mounting Options Mega

VERTICAL MOUNTING

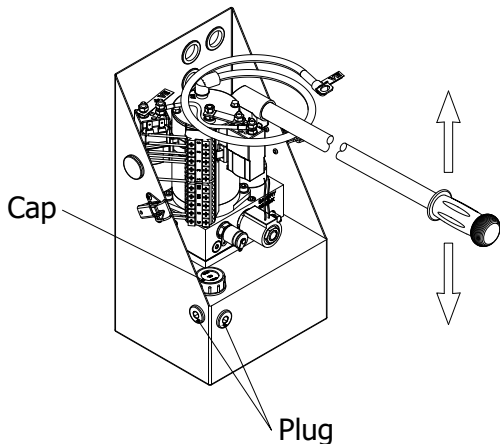

MOUNTING

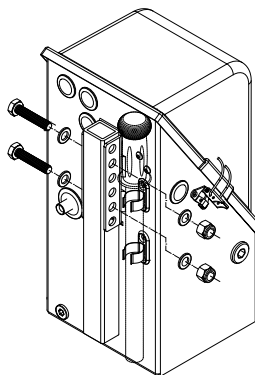

HORIZONTAL MOUNTING (ON BACK)

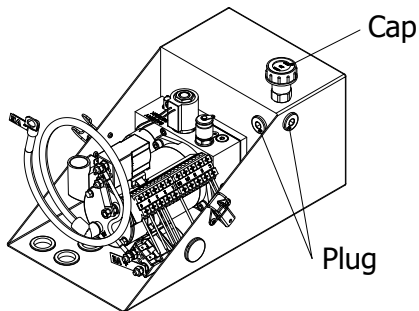

HORIZONTAL MOUNTING (ON SIDE)

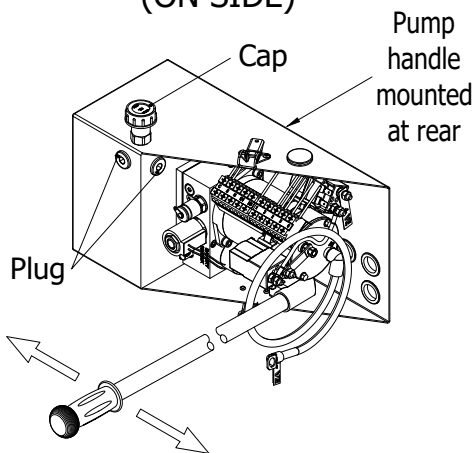

MOUNTING BRACKETS WILL VARY CONTACT PLS

7.5 Slim line Power Pack Mounting Options Mega

VERTICAL MOUNTING OPTIONS ONLY

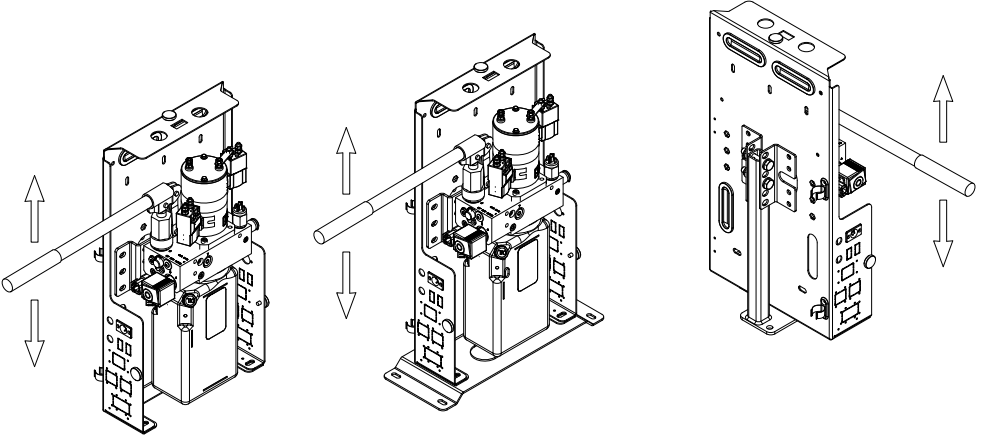

STANDARD MOUNTING

"TOP HAT" MOUNTING

"PEDESTAL" MOUNTING

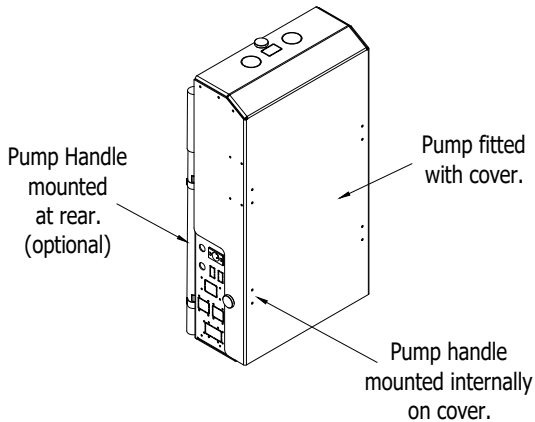



7.6 Checking the Power Pack Oil Level Mega

Ensure Pump is clean during service life and not enclosed in wet or dry road debris. Externally mounted Pumps should not be submerged in water! Mud Guards or Splash protection is recommended for externally mounted pumps where possible. Oil level & condition must be visually checked during every service interval for contamination, every three years the oil tank MUST be completely drained, thoroughly cleaned and then refilled with filtered PLS Blue oil.

Before checking the Oil Level, ensure the vehicle is securely parked on flat level ground; operate the lift so that the lift platform sits completely on the ground.

Metal tank with a dip stick:-

Ensure any loose dirt is removed from around the tank filler cap with a clean dry cloth. Remove Oil filler cap and wipe any residual oil from the dip stick using a clean dry cloth. Re-fit the dip stick fully into the Oil filler, remove and then check to see where the oil is indicated on the dip stick. If the oil is on or below the min mark then top up slowly with filtered PLS Blue oil only, repeat checking procedure as above until the oil is mid way between min/ max levels.

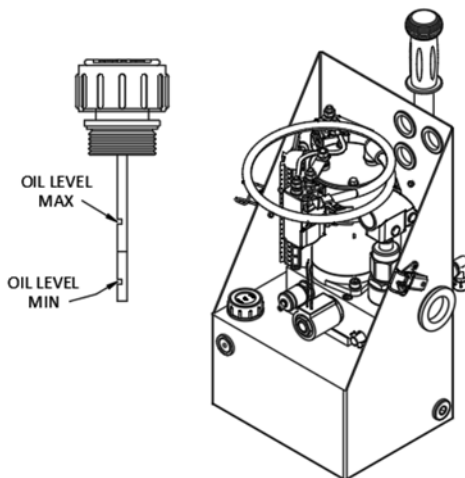

Plastic tank with NO dip stick:-

Ensure any loose dirt is removed from around the tank filler cap and oil level indicator marks with a clean dry cloth. Visually check the oil level within the translucent oil tank, if the oil is on or below the min mark then top up slowly with filtered PLS Blue oil only, repeat checking procedure as above until the oil is mid way between min/ max levels.

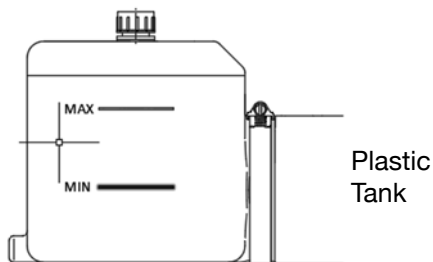

7.7 Hydraulic and Electrical Fittings Mega

HYDRAULICS FITTING

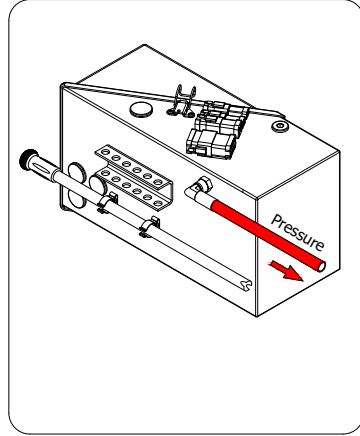
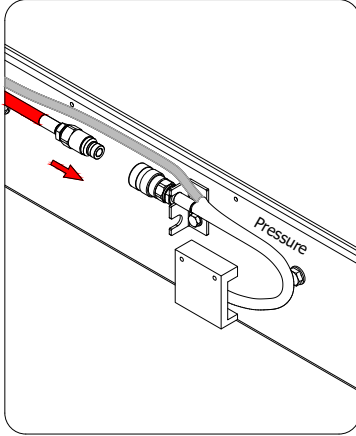

ELECTRICS FITTING

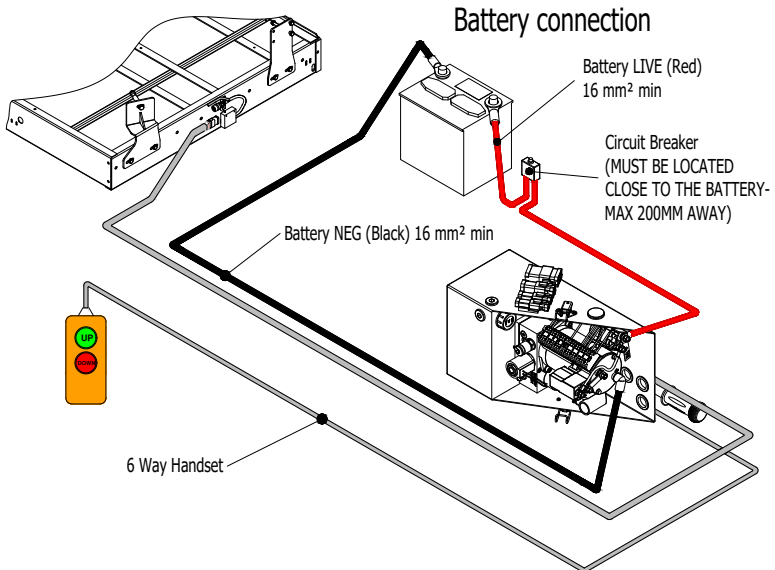



Installation

7

7.8 Floor Height Adjustment Mega

1. Loosen Lock Nut

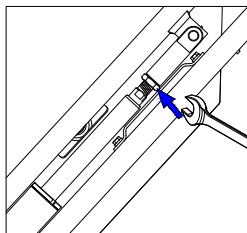

2. Adjust Floor Height

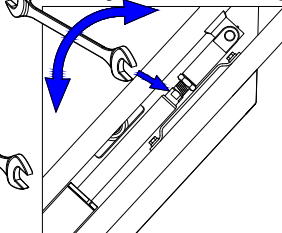

↑ Anti Clockwise = UP

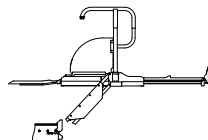

↓ Clockwise = DOWN

3. Check Thread Length

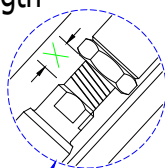
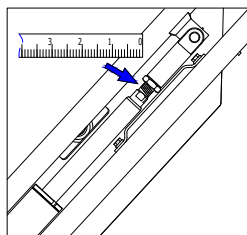

Thread Length 5mm To 20 mm ✓

Thread Length Over 20 mm ✗



4. Lock

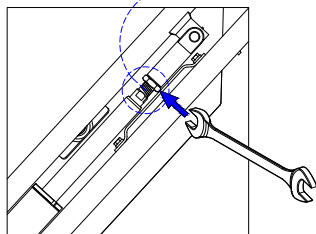

5. Check Floor Height

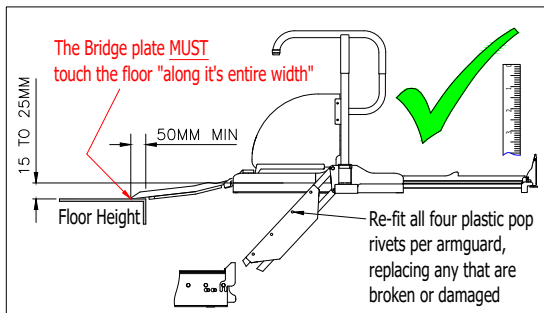

6. Check Cylinder Balance (kick)

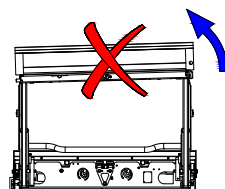
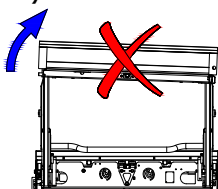
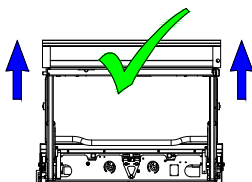

7.9 Bridge Plate Adjustment Mega

Access is gained from underneath the platform

1. Lift position for Relax and Adjustment

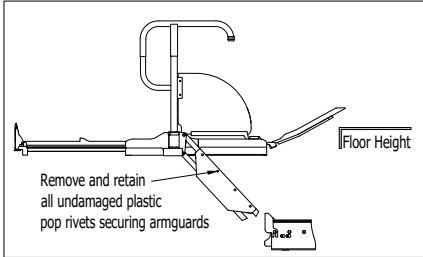

2. Loosen Grub Screw

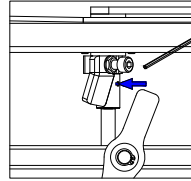

3. Loosen Lock Nut

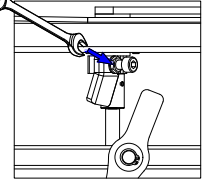

4. Adjust Bridge Plate

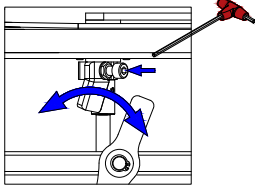

Anti Clockwise - Bridge Plate Up

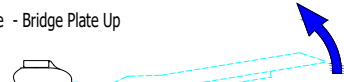
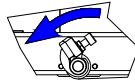

Clockwise - Bridge Plate Down

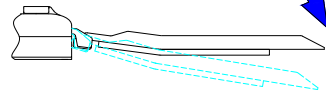
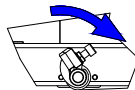

5. Lock

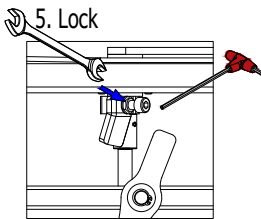

6. Check. Power Lift to Maximum Up Position

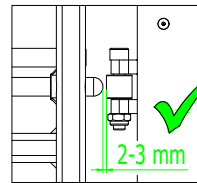
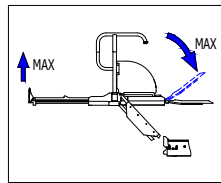

The Bridge plate **IS** touching the floor "along it's entire width"

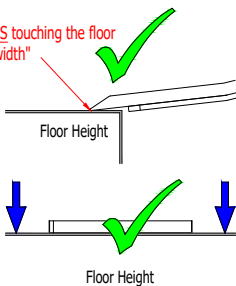

The Bridge plate is **not** touching the floor.

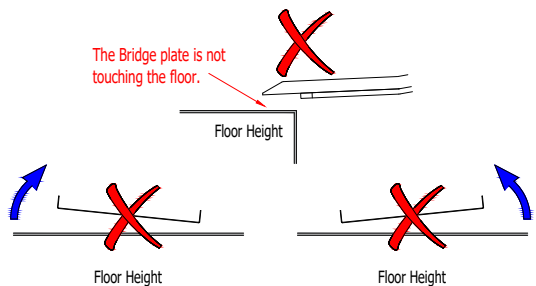



7.10 Switch Bracket Adjustment Mega

Switch adjustment & operation must be checked during installation, servicing and maintenance.

Dim A is measured from the front outer face of the carriage to the edge of the switch bracket

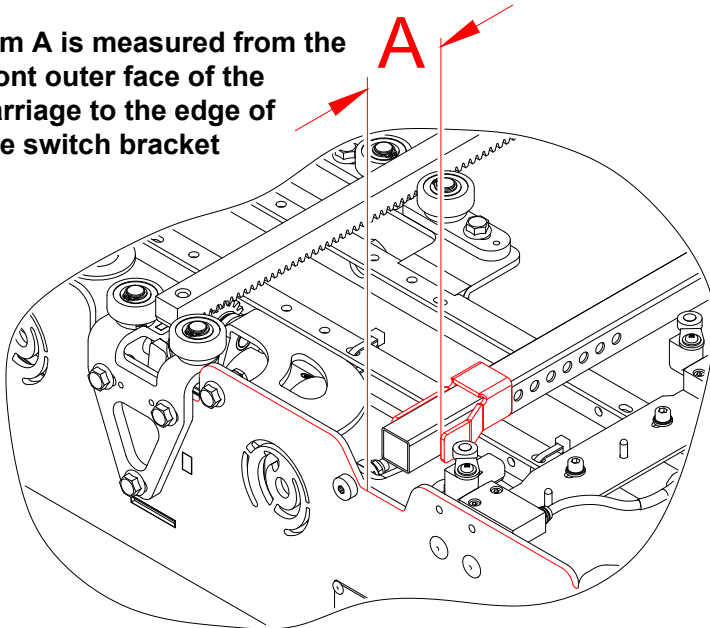

Set dim 'A' between 35mm & 45mm.
Check if carriage lock is engaging correctly; change to suit if required.

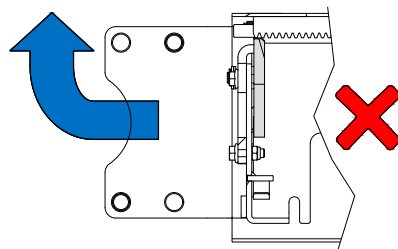
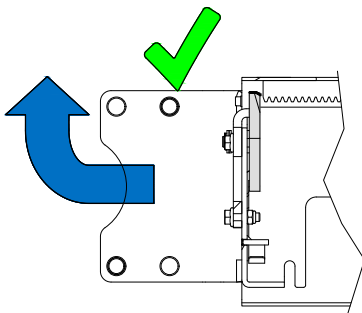

7.11 Weight Test Mega

Dynamic

1 Reduce Power Pack Pressure

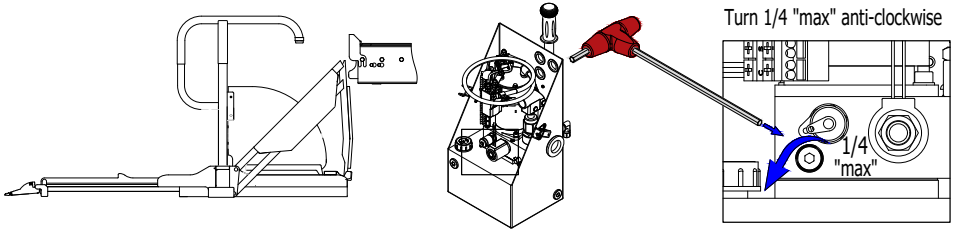

2 Power Up Lift, Increase Pressure Gradually To Lift

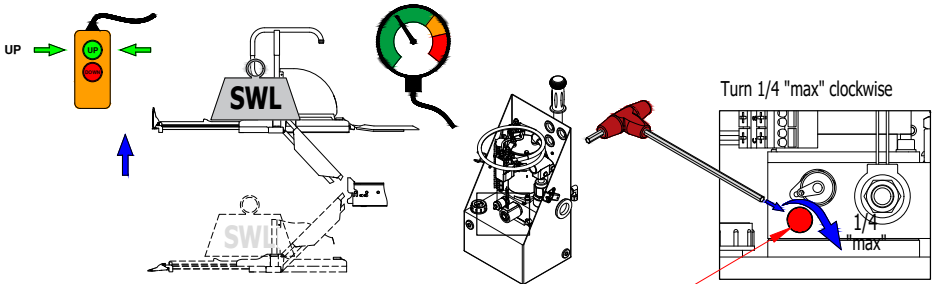

ENSURE "RED" SECURITY PLUG IS CORRECTLY
FITTED AFTER FINAL ADJUSTMENTS

3 Power Down Lift

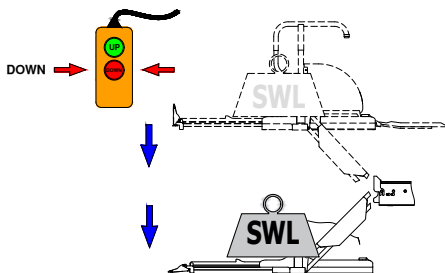

Check Manual Pump

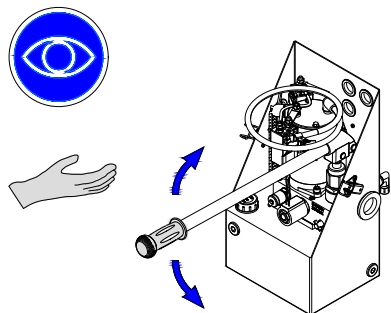



Installation

7

7.12 Weight Test Mega

Overload

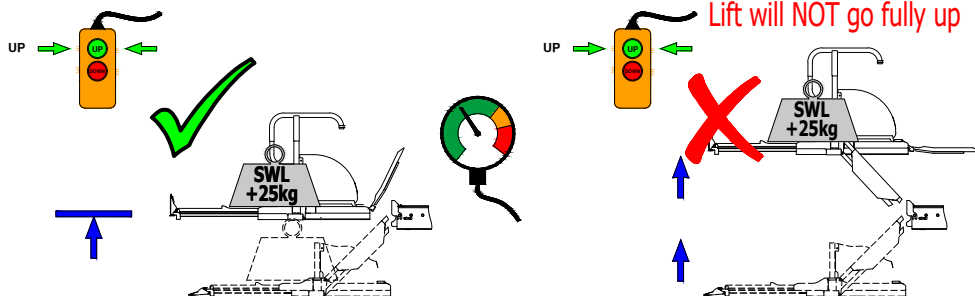

Drift

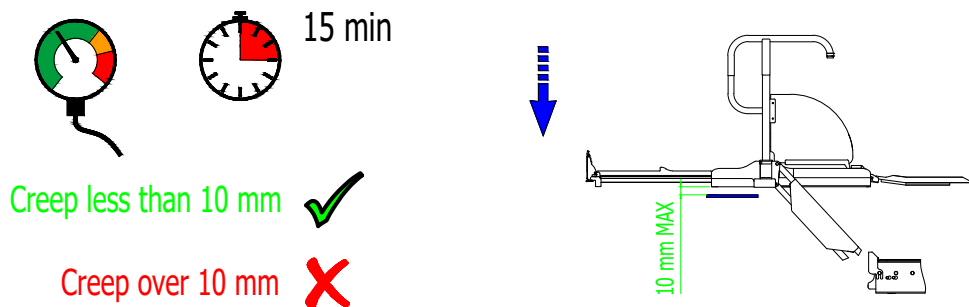

Static

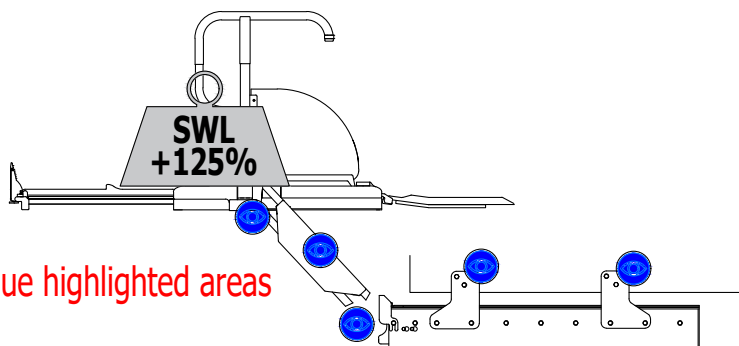
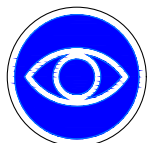

7

Installation



7.13 Installation Check List Mega Fitted in Bottom Locker

 Coach Lift Installation Check Sheet		QF152/A 02/12/21		Lift No :	
				Vehicle reg: Or chassis no	
Engineer name :		Date :			
Customer Details :					
Address:					
Check no.	Sign off the completed work (it may be agreed for customer to complete, if so tick customer)	Filter	Customer	Yes	No
1	Does lift match CAD drawing for coach (Check lift is correct, if no drawing in pack state in comments) <i>Engineer's comments</i>				
2	Is the coach prepared with CORRECT structural steel for lift to be mounted (Box rear brackets will be subject to over 3 tonnes of force UP each) <i>Engineer's comments</i>				
3	Is all structural steel work correctly painted / undersealed (No raw steel used) <i>Engineer's comments</i>				
4	All 4 lift brackets fixed to cassette with CORRECT length track bolts. <i>Engineer's comments</i>				
5	Where required, the correct spacers or packers to drawings are used. <i>Engineer's comments</i>				
6	Mounting bolts in each bracket are: M10 or M12 (2 off) OR M16 or M20 (1 off) each bracket <i>Engineer's comments</i>				
7	If plain nuts are used they must be thread-locked, and torque sealed. <i>Engineer's comments</i>				
8	All installation nuts & bolts are correctly torque set. <i>Engineer's comments</i>				
9	External box hose & cable correct length, routed and secured (Additional length can be coiled up if safe to do so) <i>Engineer's comments</i>				
10	Powerpack location correct so lift platform can be fully seen whilst manually overriding. <i>Engineer's comments</i>				
11	Powerpack mounted securely enough to be manually pumped. <i>Engineer's comments</i>				
12	Powerpack mounted fully 'plug & play' (easy to swap out in service, all plugs at pump end). <i>Engineer's comments</i>				
13	Powerpack pump handle correctly clipped in. <i>Engineer's comments</i>				
14	Powerpack OIL topped up to correct level. <i>Engineer's comments</i>				
15	Powerpack C&S link wire removed. <i>Engineer's comments</i>				
16	Live cable correctly fitted to vehicle source (eg switched live on brass fitting). <i>Engineer's comments</i>				
17	Live cable correctly surge protected (PLS 40 amp circuit breaker or OEM fuse). <i>Engineer's comments</i>				
18	Live cable correctly sleeved and routed and secured. <i>Engineer's comments</i>				
19	Earth cable connection to chassis or battery to a high standard (paint removed). <i>Engineer's comments</i>				
20	Auxiliary handset plug fitted in convenient place to operate lift. <i>Engineer's comments</i>				
21	Bridging plate does not impede with locker flap / cover. <i>Engineer's comments</i>				



Installation

7

Check no	Sign off the completed work (it may be agreed for customer to complete, if so tick customer)	Fitter	Customer	Yes	No
22	Handset clean and wired correctly (Fully tested). <small>Engineer's comments</small>				
23	Handset holster fitted. <small>Engineer's comments</small>				
24	Lift isolated from vehicle when in use: Door switch or OEM logic. <small>Engineer's comments</small>				
25	Top and bottom sheet adequately fixed. <small>Engineer's comments</small>				
26	Lift UP height correctly set to vehicle floor height. <small>Engineer's comments</small>				
27	Bridging plate landing ON vehicle floor (No gap or trip hazard). <small>Engineer's comments</small>				
28	Platform extension end correctly lands on GROUND (Loaded and unloaded). <small>Engineer's comments</small>				
29	Lift operation board fitted with appropriate fastenings (not double sided tape). <small>Engineer's comments</small>				
30	Lift manual override board fitted with appropriate fastenings. <small>Engineer's comments</small>				
31	Lift sticker pack left with vehicle (Stickers fitted if / where possible). <small>Engineer's comments</small>				
32	Weight test lift and fill in certificate. <small>Engineer's comments</small>				
33	Set powerpack pressure relief valve correctly with lift SWL weight. <small>Engineer's comments</small>				
34	Re-check floor height and bridge-plate setting to vehicle floor (completed with and without weight). <small>Engineer's comments</small>				
35	Lift clean and lubricated (correct ACF-50 or silicone). <small>Engineer's comments</small>				
36	Photographs taken of complete installation (Inc all worked on parts). <small>Engineer's comments</small>				
37	Working area cleaned, floor swept to a satisfactory level, rubbish removed. <small>Engineer's comments</small>				
38	Relevant Manager contacted to inspect installation and sign off paperwork. <small>Engineer's comments</small>				

Fitter Name & Signature: _____

Customer Name & Signature: _____



7.14 Torque Settings in Nm Mega

Thread Size	Tightening Torque Nm		
	Property Class		
HTS	8.8	10.9	12.9
M4	2.9	4.1	4.95
M5	5.75	8.1	9.7
M6	9.9	14.0	16.5
M8	24.0	34.0	40.0
M10	48.0	67.0	81.0
M12	83.0	117.0	140.0
M14	132.0	185.0	220.0
M16	200.0	285.0	340.0

Thread Size	Tightening Torque Nm		
	Property Class		
HTS Hex Flange	8.8	10.9	12.9
M6	9.0	14.7	16.8
M8	20.0	35.6	41.0
M10	40.0	70.6	81.0

Thread Size	Tightening Torque Nm	
	Property Class	
Stainless Steel	A2-70	A4-80
M4	2.6	3.5
M5	5.1	6.9
M6	8.8	11.8
M8	21.4	28.7
M10	44.0	58.0
M12	74.0	100.0
M14	119.0	159.0
M16	183.0	245.0

Thread Size	Tightening Torque Nm
Hydraulic Fitting BSP	
1/8	17.0
1/4	34.0
3/8	47.0



Operation

8

8.1 Standard Operating Procedure Mega

<p>1 Open Lift Cover and Lock Open</p> <p> <input type="checkbox"/> PASSENGER VEHICLE DOOR <input type="checkbox"/> OPEN LIFT COVER TO ACCESS LIFT </p>	<p>2 Power Lift Out</p>	<p>3 Power Up to 150+ mm</p>	<p>4 Raise Up Handrails and Open Throw Overs</p> <p>Ensure Handrails are Correctly Engaged</p>
<p>5 Pull Extension Fully Out</p> <p>Ensure Aluminium Drops and Locks</p>	<p>6 Power Down</p>	<p>7 Power Up</p>	<p>8 Power Lift Up/Down to 150+ mm To Stow</p>
<p>9 Lift Up Aluminium and Push Extension Fully In</p>	<p>10 Close Throw Overs and Fold Down Handrails</p> <p>Pull Plungers To Unlock Handrail</p>	<p>11 Stow Lift</p> <p> Click Ensure Lock Is Fully Engaged </p> <p>CAB SWITCH MUST BE TURNED OFF AFTER LIFT USE</p>	<p>11 Stow Lift</p>

8.2 Manual Override Procedure Mega

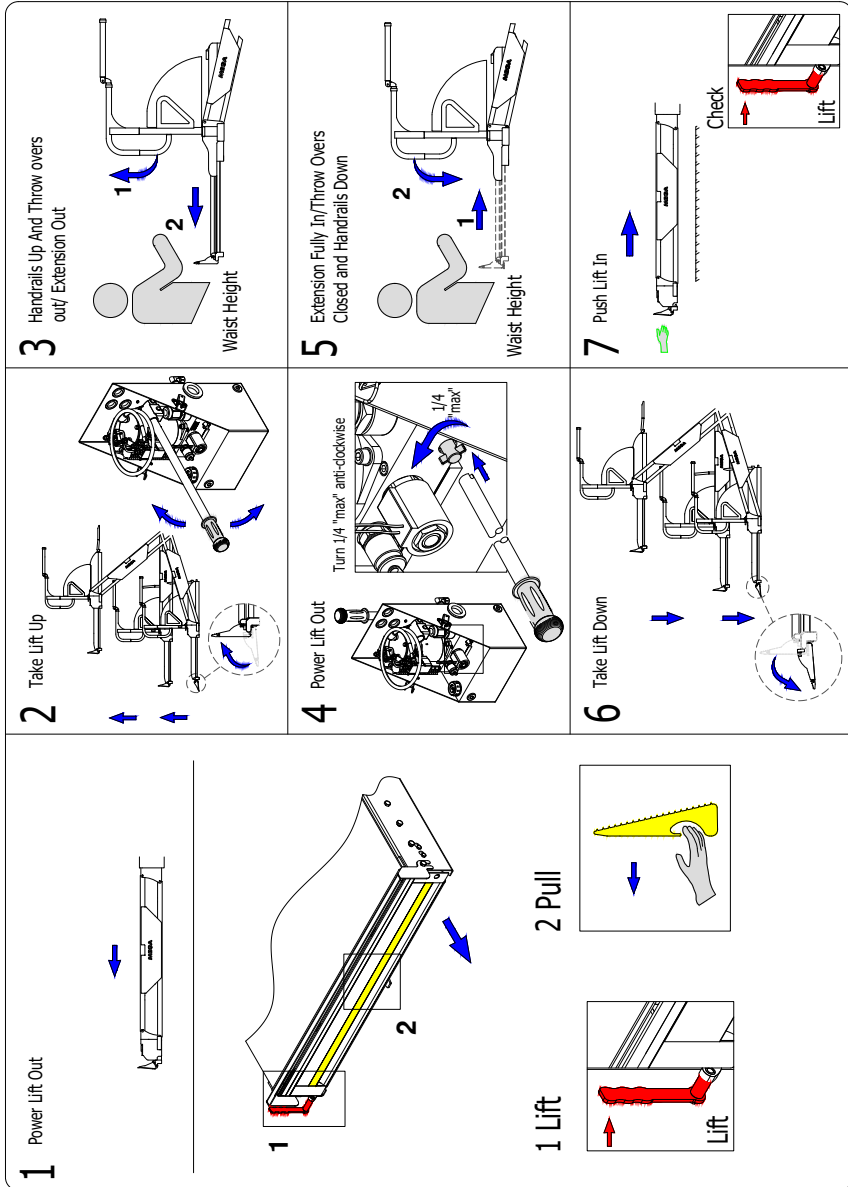

9.1 Cleaning Instructions Mega

Great care needs to be taken during the cleaning process, all cleaning is to be carried out by hand using a gentle cloth or sponge soaked in non-aggressive detergent and then rinsed with a cloth dampened with water. Ensure all moving parts are re-lubricated where necessary.



**DO NOT USE AGGRESSIVE DETERGENTS.
DO NOT USE WATER JETS OR HOT WATER JET CLEANERS.**

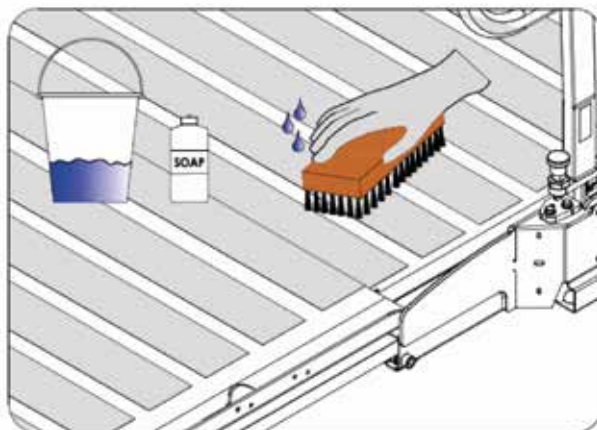
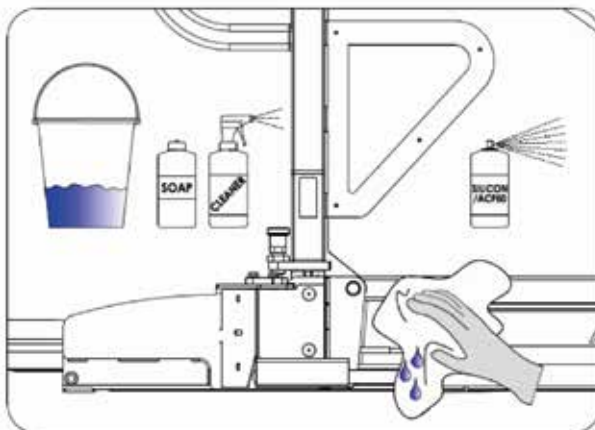

Check and re-lubricate parts as described in section 10.7



10.1 Warranty Mega

Warranty Cover & Period

The PLS Warranty covers parts and labour, and is effective for 36 months from the date of initial commission by PLS or a certified authorised engineer.

If the date of initial commission is in excess of 90 days from date of despatch, the warranty will start from the date of despatch.

Procedure:

- To qualify for this warranty it is necessary to register the Lift and Vehicle details on line www.passengerliftservices.co.uk or via post within 45 days of the initial LOLER inspection.
- An operator requiring attention to a unit will contact PLS directly and quote the lift serial number.
- PLS will then instruct a company engineer or an authorised approved Service Agent by issuing an official order number to affect the repair.

NB: ANY WORK CARRIED OUT WITHOUT AUTHORISATION WILL NOT BE REIMBURSED.

Conditions:

Warranty does not extend to lifts that have not been regularly serviced by a PLS engineer, or a factory trained and authorised engineer. This includes the 6 monthly LOLER inspection and separate weight test, which must be current at the date of the Warranty Claim.

All previous LOLER and Weight Test Certificates must have been copied to PLS and run concurrently.

The lift must be made available during the hours of 08.30 and 17.00, Monday to Friday excluding public holidays.

No delivery costs or travel time will be reimbursed except by prior agreement, as specified on the original Purchase Order.

The initial Warranty period applies to original parts only. Replacement parts changed under warranty, and new parts purchased, carry 12 months warranty only.

New parts that have been purchased and require a warranty repair will require either a copy of the original Purchase Order or details of the original Purchase Order number to qualify.

The serial number(s) for the component claiming warranty must match the serial number(s) recorded to the lift it was originally fitted to.

If a customer has an invoice unpaid beyond PLS terms and conditions or is in dispute customers lift will not be visited.

Warranty Exclusions:

Hydraulic Power packs that are fitted to the exterior of the vehicle only carry 12 months warranty (if cover is missing warranty void).

Hydraulic Power packs fitted to the interior of the vehicle qualify for the 24 months warranty.

The following are all excluded from warranty:

Consumable parts e.g. Fuses, Bulbs, Electrical Connectors, Bearings, Hydraulic Hoses (with the exception of manufacturing defects). Fastenings which should be checked at the service intervals. Driver misuse Accident damage. Items that are subject to the level of wear & tear which would normally involve replacement during normal service, maintenance and operating conditions.

Handsets carry 12 months warranty only.

No claim will be accepted for:

Replacement vehicle hire or loss of earnings.

The Warranty Agreement does not supersede the Suppliers liability for all components as defined in the Sale of Goods act 1982.

Months 24 to 36 of the Warranty:

The vehicle will be required to be returned to the PLS Factory for 'free of charge' warranty work.

When this is not possible, labour and travel will be charged at the current PLS hourly rate, whether it is a PLS engineer or an agent working on behalf of PLS Ltd that conducts the repair.

If an agent is used, it will be at the discretion of PLS Ltd as to who will affect the repair.

Any parts sent to an agent for warranty work within the 24-36 Month period, will incur the relevant courier costs at commercial rates, and will be at the expense of the customer.

Extended Warranty:

Extended Warranty is available for months 37-60 with a written agreement of PLS Ltd, initiated BEFORE month 37 starts.

This warranty will follow the same basis as the 24-36 month period.

Extended Warranty does not include Power packs, motors, hydraulic cylinders and hoses.



Service & Maintenance

10

10.2 Loler Mega



This lifting equipment is covered by the
“Lifting Operations & Lifting Regulations Act 1998. “LOLER”.

It is the lift operating company or duty holders responsibility to ensure that
at regular **SIX** monthly intervals this equipment is **INSPECTED,**
SERVICED & WEIGHT TESTED by a competent tail lift engineer.

For more information, please contact
PLS Service Department direct line:

0121 559 0466



10.3 Daily Inspections Mega

Lift Inspection checks are required on a DAILY basis by the lift operating company. The working life of your lift will be greatly prolonged if these steps are adhered to. This should include the following:

Daily Inspection Check List		Lift no:
		Vehicle Reg:
Engineer's Name:		Date:
Customer Details:		
Address, Contact:		
Tel Number:		OK
1	Check oil level visually using the dip stick or against the oil level indicator marks on the oil tank.	
2	Check for oil contamination, usually a white creamy liquid on the underside of the filler cap, or visible water.	
3	Visually check for any leaks or damage.	
4	Check for obvious signs of damage, and notify as manager if necessary.	
5	Ensure that the Operation instructions are visible.	
6	Ensure the hand pump handle is present.	
7	Ensure the Handset control is working correctly and there are no signs of damage.	
8	Ensure the Platform is clean and dry.	
9	Ensure the Box Lock is working correctly.	
10	Ensure the Carriage centre lock is working correctly.	
11	Ensure the Handrails are clean, working correctly and rust free.	
12	Ensure the Handrail guards are present and undamaged.	
13	Ensure the Roll-Off-Ramp operates correctly and lands on the ground.	
14	Ensure the warning lights are operating correctly before using the lift (If fitted).	

IF IN DOUBT, CONTACT THE MANUFACTURER



Service & Maintenance

10

10.4 Weekly Inspections Mega

Lift Inspection checks are required on a weekly basis by the lift operating company. The working life of your lift will be greatly prolonged if these steps are adhered to. This should include the following:

Weekly Inspection Check List		Lift no:
Engineer's Name:		Vehicle Reg:
Customer Details:		Date:
Address, Contact:		
Tel Number:		OK
1	Check oil level visually using the dip stick or against the oil level indicator marks on the oil tank.	
2	Check for oil contamination, usually a white creamy liquid on the underside of the filler cap, or visible water.	
3	Visually check for any leaks or damage.	
4	Check for obvious signs of damage, and notify as manager if necessary.	
5	Ensure that the Operation instructions are visible.	
6	Ensure the hand pump handle is present.	
7	Ensure the Handset control is working correctly and there are no signs of damage.	
8	Ensure the Platform is clean and dry.	
9	Ensure the Box Lock is working correctly.	
10	Ensure the Carriage centre lock is working correctly.	
11	Ensure the Handrails are clean, working correctly and rust free.	
12	Ensure the Handrail guards are present and undamaged.	
13	Ensure the Roll-Off-Ramp operates correctly and lands on the ground.	
14	Ensure the warning lights are operating correctly before using the lift (If fitted).	

IF IN DOUBT, CONTACT THE MANUFACTURER



10.5 Monthly Inspections Mega

Lift Inspection checks are required on a MONTHLY basis by the lift operating company.

The working life of your lift will be greatly prolonged if these steps are adhered to.

This should include the following:

Monthly Inspection Check List		Lift no:
		Vehicle Reg:
Engineer's Name:		Date:
Customer Details:		
Address, Contact:		
Tel Number:		OK
1	Check oil level visually using the dip stick or against the oil level indicator marks on the oil tank.	
2	Check for oil contamination, usually a white creamy liquid on the underside of the filler cap, or visible water.	
3	Check for obvious signs of damage, and notify as manager if necessary.	
4	Ensure that the Operation instructions are visible.	
5	Ensure the hand pump handle is present.	
6	Ensure the Handset control is working correctly and there are no signs of damage.	
7	Ensure the Platform is clean/ dry & Platform extension legs are correctly lubricated using ACF-50 Silicone spray.	
8	Ensure the Box Lock is working correctly & lubricated using ACF-50, or Silicone spray.	
9	Ensure the Bridge plate is working correctly & lubricated using ACF-50, or Silicone spray.	
10	Ensure the Bridge plate springs are correctly lubricated using copper slip.	
11	Ensure the Carriage centre lock is working correctly.	
11	Ensure the Handrails are clean, working correctly and rust free.	
13	Ensure the Handrail guards are present and undamaged.	
14	Ensure the Handrail bases/ mechanisms are working correctly & lubricated using ACF-50, or Silicone spray.	
15	Ensure the Roll-Off-Ramp operates correctly and lands on the ground.	
16	Ensure Micro switch is working correctly & lubricated using ACF-50, or Silicone spray.	
17	Ensure the warning lights are operating correctly before using the lift (If fitted).	

IF IN DOUBT, CONTACT THE MANUFACTURER



Service & Maintenance

10

10.6 Six Monthly Inspections Mega

For Factory Trained Lift Engineers

As monthly safety checks plus:

Six Monthly Inspection Check List		Lift no:
		Vehicle Reg:
Engineer's Name:		Date:
Customer Details:		
Address, Contact:		
Tel Number:		OK
1	Check all fixing bolts and brackets connecting lift onto vehicle chassis.	
2	Remove pump box cover and check hydraulics / electrics for wear or damage.	
3	Check lifting cylinders for leaks, change seals if necessary. Adjust/ tighten hoses if required (35 N/m of torque for hydraulic fittings).	
4	Remove outside 'arm side guard' cover. Check bridge plate gas strut operation. Check all linkages, fittings and wheels for wear. Tighten & replace if necessary.	
5	Check all visible hoses and fittings for leaks or damage.	
6	Check handrail fittings are tight.	
7	Check condition/security of arm side guards.	
8	Check all fittings are tight particularly the arm pins.	
9	Check bridge plate and platform hinges for correct operation.	
10	Check roll-off ramp assemblies for correct operation.	
11	Check vertical stow rubber for wear (located in rear corners of platform).	
12	Check condition of SWL sticker and other lift decals.	
13	Coat all electrical connections with petroleum jelly or proprietary electrical grease.	
14	Check hand pump operation, lubricate all pivot points. REMEMBER TO RETURN MANUAL-TAP(S) TO THEIR ORIGINAL POSITION.	
15	Perform weight test in accordance with current Loler standards.	
16	Ensure that all grease points, Cam followers, Centre rack, Centre bearing assembly & Carriage Drive pinions are correctly lubricated.	

IF IN DOUBT, CONTACT THE MANUFACTURER



10.7 Lubrication Mega

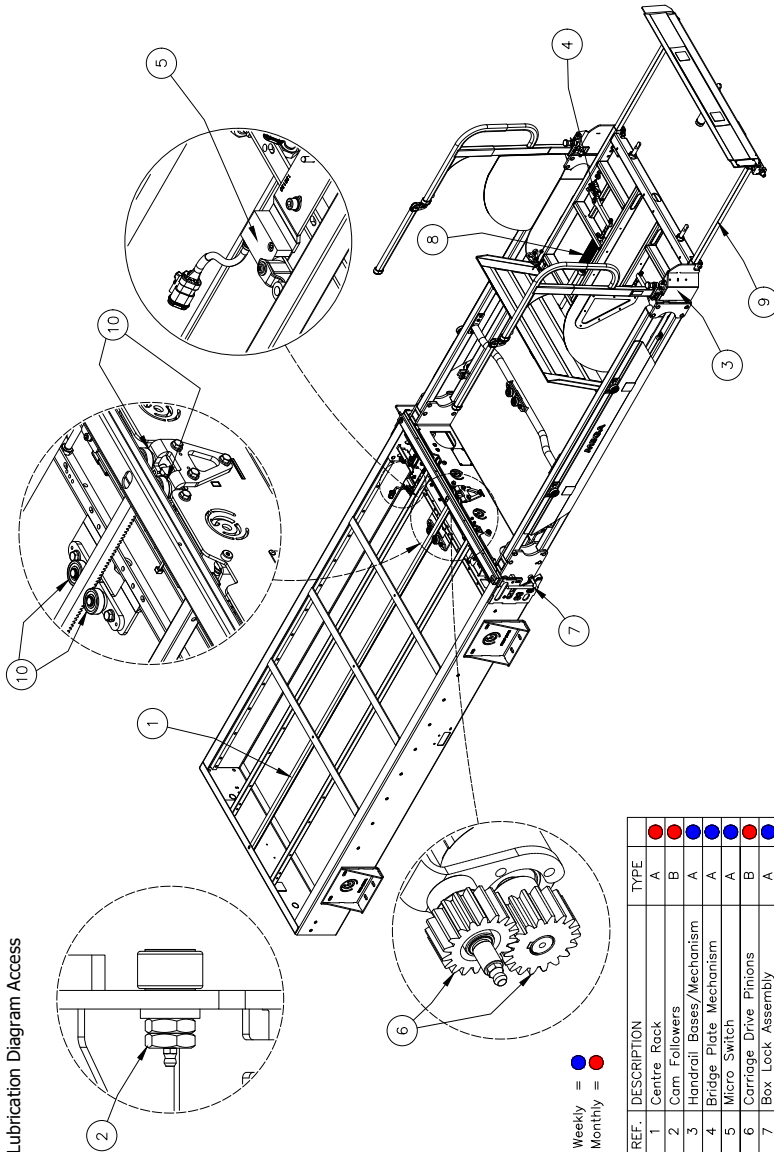

Lubrication Diagram Access

Weekly = ●
Monthly = ●

REF.	DESCRIPTION	TYPE
1	Centre Rack	A ●
2	Cam Followers	B ●
3	Handrail Bases/Mechanism	A ●
4	Bridge Plate Mechanism	A ●
5	Micro Switch	A ●
6	Carriage Drive Pinions	B ●
7	Box Lock Assembly	A ●
8	Bridge Plate Springs	A ●
9	Platform Extension Legs	C ●
10	Centre Bearing Assy	B ●
	All Other Springs	A ●

TYPE	LUBRICATION SPECIFICATION
A	ACF50
B	LITHIUM GREASE EP 2
C	HEAVY DUTY SILICON TYPE 40

*Lift MUST be cleaned, lubricated and maintained in accordance with current LOLER regulations.
Do not Grease any components externally as this attracts dirt and dust.



Service & Maintenance

10

10.8 Check List Mega

LOLER / SERVICE Repair Check List		Lift no:		
Engineer's Name:		Vehicle Rag:		
Customer Details:		Date:		
Address, Contact:				
Tel. Number:		Poor	Ok	Good
1	Ramp stop (roll-off) operation/condition			
2	Condition of ramp stop cylinder (corrosion, leaks, loose caps)			
3	Bridging plate operation/condition			
4	Carriage lock and rocker(s) working correctly			
5	Platform stability			
6	Platform extension operation (stops tight)			
7	Platform stowage set correctly			
8	Handrail and side guard operation/condition			
9	Cleating and wearstrip condition			
10	All set pins secure/ Grub screws tight			
11	All fasteners tight			
12	In/Out Motor operation/condition/ check top cog			
13	Condition of all bearings and camfollowers/ grease x 4			
14	Umbilical hose condition			
15	Check lift isolator (cab or door switch)			
16	Condition of lifting cylinders (corrosion, leaks, loose caps)			
17	Up/Down hydraulic pump operation/condition (relief valve) with SWL on lift			
18	Hand pump operation/condition/ check tightness			
19	All hoses in good condition/ arm hose/ cylinder hoses and platform pipe & hose.			
20	Hydraulic fittings in good condition/ ports on power pack tight			
21	Wiring loom condition (crimps, fuse holder, earth wires, etc)			
22	Box lock operation/condition			
23	Condition of box tracks (not bent or indented)			
24	Top and bottom sheets secure			
25	Box brushes present and secure			
26	Condition of stowage box and fitting brackets			
27	Lift correctly lubricated/ cam followers / extension/ switches and cam and cranks.			
28	If powermatic, in/out operation & switches set correctly			
29	Speed of operation acceptable			
30	Handset condition			
31	Labels and operating instructions			

10

Service & Maintenance



33	LOLER sticker correctly fitted and displayed			
34	Fluid levels to correct level.			

Engineers Comments



11.1 Correct Instructions Mega



PLS Environmental & Lift End of Life Policy:

All materials used in the construction of our products are widely recycled. The Company also offer a full 100% and certificated service which provides for your Lift to be sustainably recycled, please enquire for more information.

Generally the machine should be disassembled and identical materials grouped together these must then be disposed of in accordance with local environmental legislation.

Contact the local Authority to ensure that specific materials such as lubricants, electrical/ electronic components are disposed of correctly.



YOU MUST RETURN THE MACHINE ID PLATES AND ANY OTHER CONNECTED DOCUMENTS TO PLS WHEN THE PRODUCT HAS BEEN RECYCLED.

Passenger Lift

Materials	Percentage (%)
Metal	81.6
Oil	0.56
Electrical	1.4
Plastics	3.3
Rubber	0.14
Aluminium	11.6
Hose	1.4

Information based on Average Lift

Hydraulic Power Pack

Materials	Percentage (%)
Metal	43.75
Oil	16.6
Electrical	16.6
Plastics	2.5
Rubber	0
Aluminium	18.58
Hose	2.0

Information based on Average Power Pack

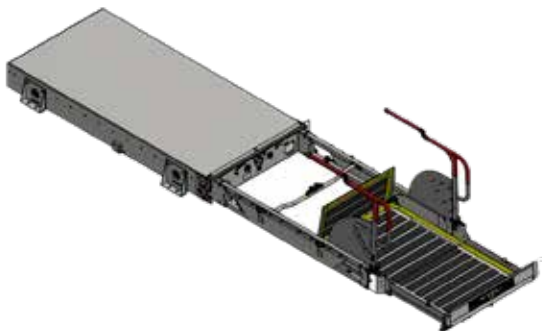



12.1 Trouble Shooting Instructions Mega

Problem	Fault	Solution
Lift not operating	Circuit breaker or fuse tripped	Reset circuit breaker or replace fuse
	Cab switch not turned on	Turn cab switch on
	Door switch sticking	Lubricate and free switch
	Low voltage	Charge battery
	Poor earth	Check battery cables & earth points
	Corrosion on crimped cables	Re-crimp cables and clean corrosion
	Loose power-pack electrical connections	Check electrical connections
	Handset failure	Replace handset
Lift stuck in box	Box lock not fully disengaged	Make sure lock handle is pulled fully up
	Lift is pressurized up in box	Press Down on handset to lower lift or open the down valve to release pressure
	Box grounded and damaged underneath	Repair / replace box
Lift not powering IN	Motor cut-off switch (In switch)	Check switch adjustment & lubricate
	Umbilical damaged	Replace umbilical cable
	Carriage solenoid failure	Replace solenoid
	Motor failure	Replace motor
	Carriage lock not lowering correctly	Check & readjust carriage lock stowing
	Carriage lock switch failure	Check switch adjustment & lubricate
Lift not powering OUT	Lift Up switch (Out switch)	Check switch adjustment & lubricate
	Umbilical damaged	Replace umbilical cable
	Carriage solenoid failure	Replace solenoid
	Motor failure	Replace motor
	Loose carriage electrical connections	Check plugs, sockets & pins
Lift not powering UP	Low oil	Add PLS Blue Hydraulic oil
	No pump pressure	Check and readjust pressure relief
	Hose burst	Replace
	Lift Up switch (Out switch)	Check switch adjustment & lubricate
	Manual release left open	Close manual override
	Down valve stuck open (contamination)	Remove / clean and replace
	Low voltage	Charge battery
Lift not lowering DOWN	Contamination in PC Burst valves	Replace PC burst valve set
	Crash vales locked (cold weather)	Readjust crash valve gap
	Down valve not opening due to low voltage	Charge battery
	Down valve sticking (contamination)	Remove / clean and replace
	Down valve coil failure	Check / replace



Trouble Shooting

12

Problem	Fault	Solution
Platform Extension will not extend	Handrails not raised up	Raise up handrails into locked position
	Extension legs not free from stow bolts	Power lift UP to higher position
	Lack of lubrication	Lubricate moving parts
	End stops loose	Tighten end stops
	Extension pipe / hose catching in platform	Reposition hose / pipe
Platform Extension will not retract	Extension pipe / hose catching in platform	Reposition hose / pipe
	Extension legs hitting stow bolts	Power lift UP to higher position
	Lack of lubrication	Lubricate moving parts
	Extension pulled out to hard, End stops jammed on rollers	Reset, Replace extension end stops
Ramp will not deploy	Lack of lubrication	Lubricate pivot sand moving parts
	Ramp damaged	Replace
	Cylinder failure	Replace
	Air in Cylinder	Bleed out air in cylinder
Bridge Plate operation not operating smoothly / noisy	Lack of lubrication	Lubricate pivot sand moving parts
	Bridge plate parts damaged	Replace damaged parts
Bridge plate not touching vehicle floor	Push rod position incorrect	Adjust toggle joints or adjustable crank
	Cam & Crank slipped	Reset, Replace Cam & Cranks
Bridge plate not lifting to vertical position when lowering lift	Bridge plate compression springs force to low	Adjust spring collars (do not bottom out springs)
Bridge plate not lifting to vertical position when powering lift out of box	Torsion bars twisted / broken	Replace Torsion Bars
Lift platform jamming on arms when powering UP	Incorrect operation due to Under stowing extension	Lower lift and retract extension
Handrail rattling / loose	Handrail pins loose or missing	Reset, Replace pins
Handrails not locking when raised up	Handrail damaged	Replace
	Handrail lock out of adjustment	Readjust Handrail Lock
Auxiliary hand pump not working	Air in system	Bleed out air, open manual override valve and pump hand pump 10 times, close and try again



13.1 Wiring Diagram - Power Pack Mega

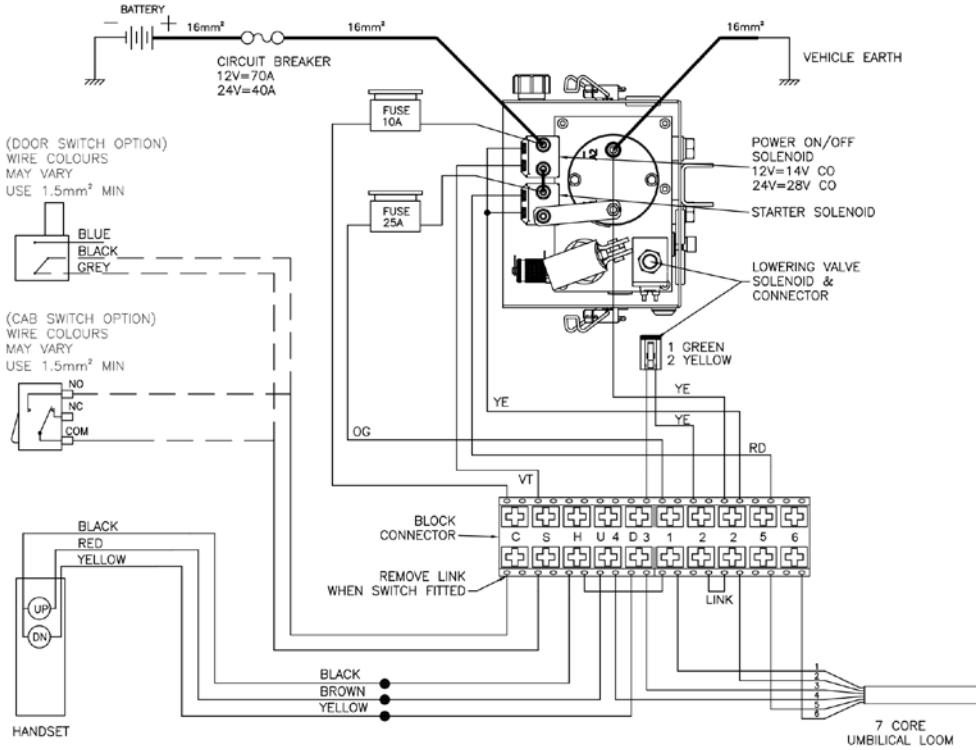



13.2 Wiring Diagram - Lift Mega

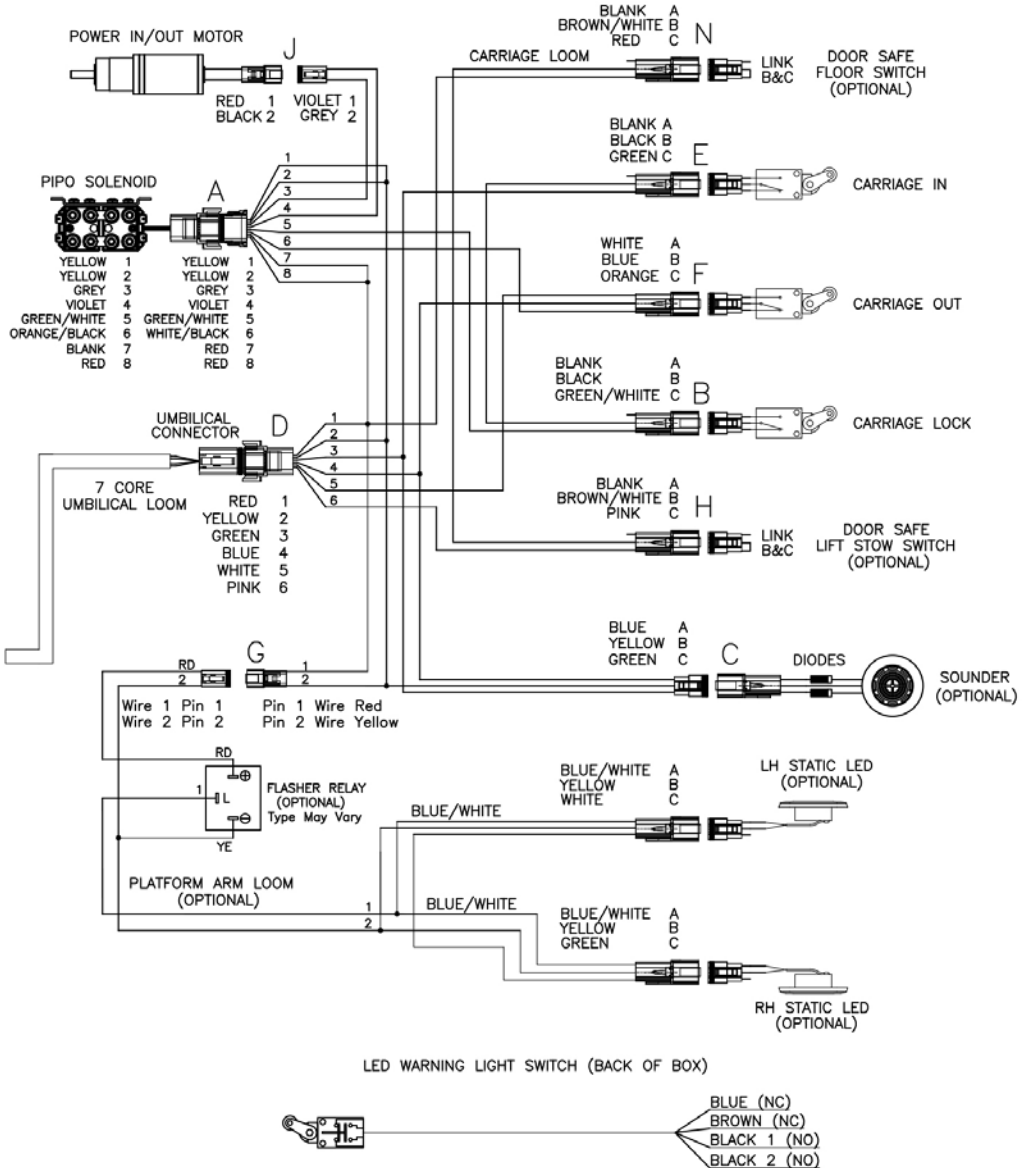

This micro switch is used to signal when the lift is IN & OUT of stow. It can be used to signal a warning light or buzzer on the dashboard. It should NOT be hardwired to the vehicle brakes.

13.3 Wiring Diagram - Buzzer Dip Switch Settings Mega

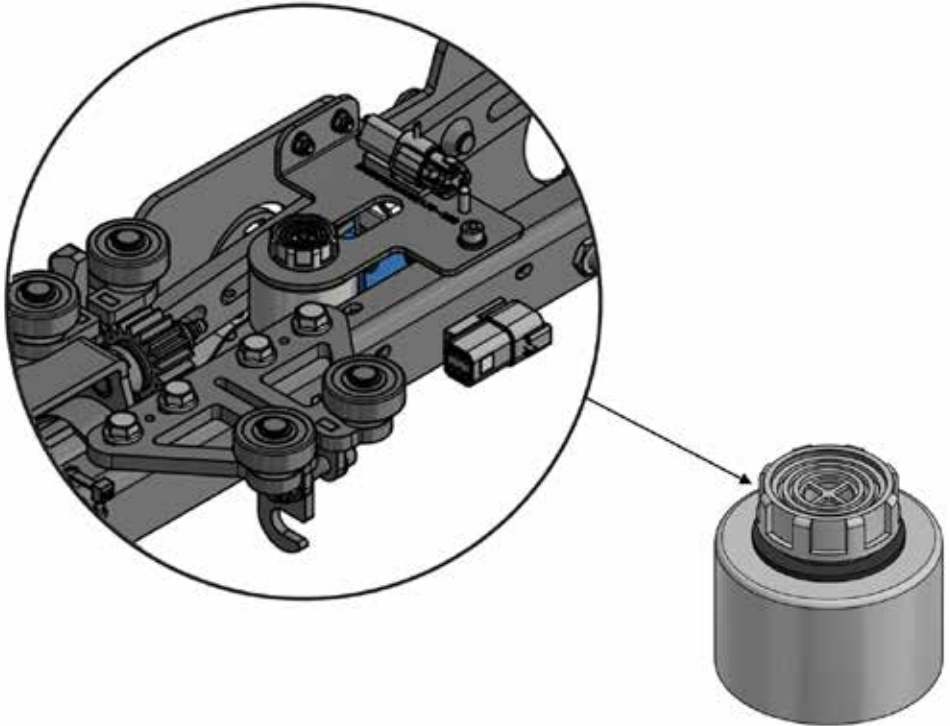

Volume Control
(Turn clockwise to increase)

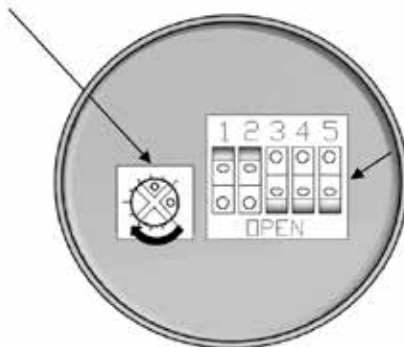

Dip Switches

Buzzer Dip Switches
1,2 Open
3,4,5 Closed

View on underside of Buzzer

13.4 Hydraulic Diagram Mega

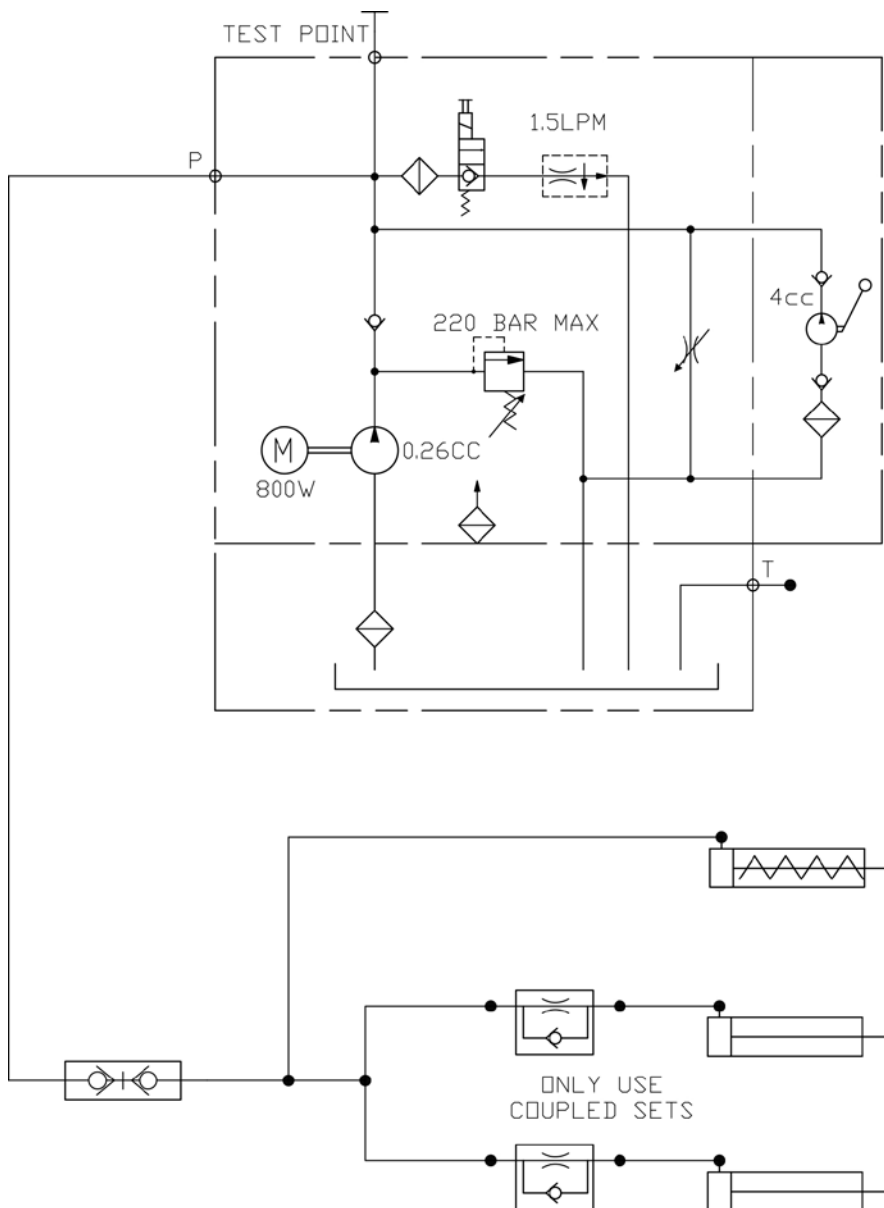



14.1 List of Spare Parts Mega



For spare parts, either, use the assembly drawings to identify the required part, then add these to the following form or contact the PLS spare parts department and talk to one of our staff.

Description:-

1. Box Assembly
2. Box Rear Switch
3. Box Lock Assembly Pre 2020
4. Box Lock Assembly
5. Box Umbilical
6. Carriage Assembly
7. In/ Out Motor Assembly
8. Front Centre Bearing & Rear Bearing
9. Carriage Switch Bracket Assembly
10. Carriage Hydraulics
11. Handrail "H" Assembly
12. Single Throw In Handrail
13. Single Throw Out Handrail
14. Lower Left Arm
15. Lower Right Arm
16. Upper Left Arm
17. Upper Right Arm
18. Arm Cylinders
19. Arm Brace
20. Bridge Plate Assembly
21. Platform "H" Single Mechanism
22. Platform Alloy
23. Platform Extension
24. Extension Alloy
25. Extension Pipe and Hoses
26. Roll-Off-Ramp
27. External Enclosed Pack, Horizontal Position
28. Internal Enclosed Pack, Vertical Position
29. Handset Kit
30. Moulded Handrail Assembly

1 Box Assembly

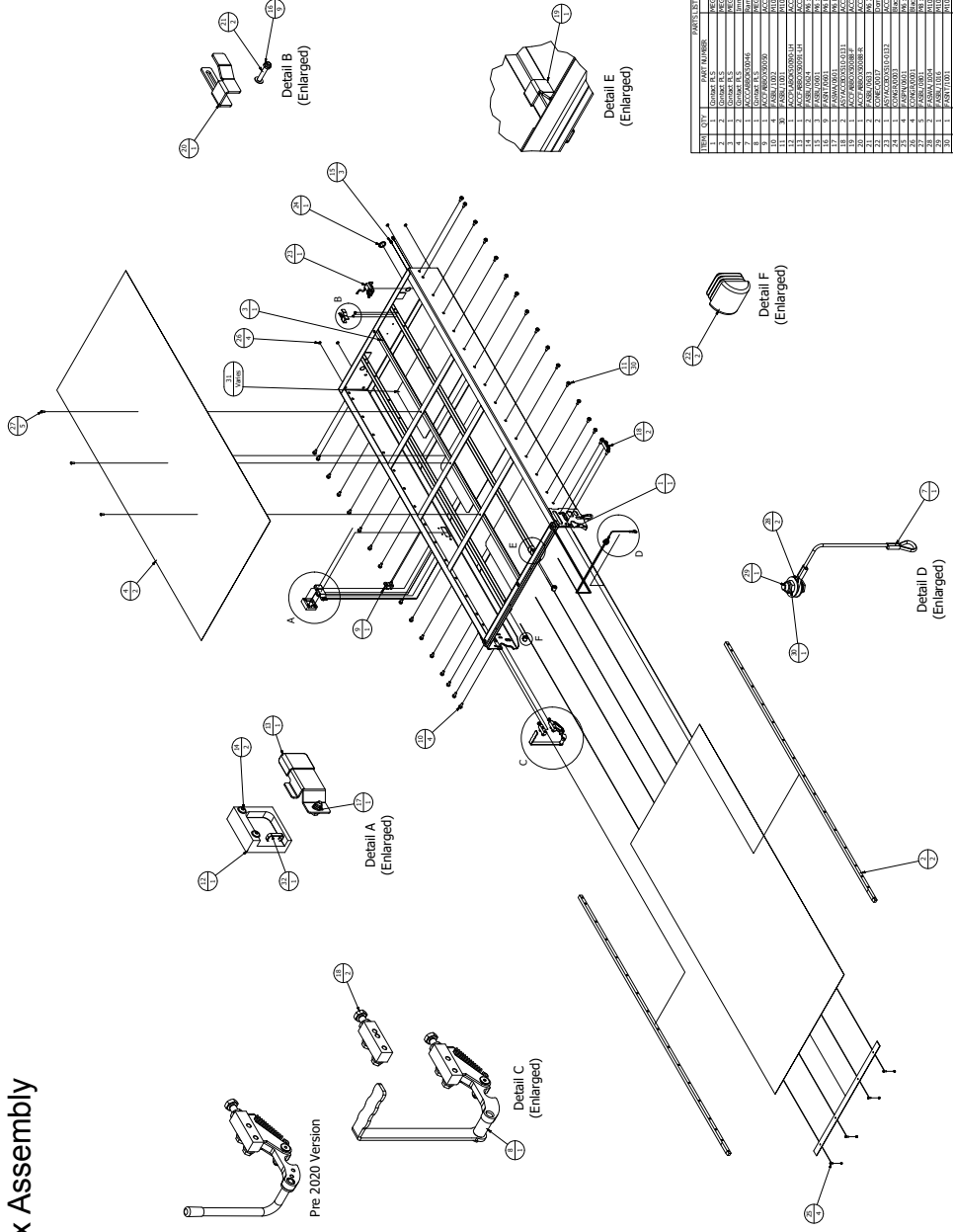

ITEM	QTY	UNIT	REVISED PARTS LIST
1	1	PC	PLATE BRASS 3/16"X1/2"
2	1	PC	PLATE BRASS 3/16"X1/2"
3	1	PC	PLATE BRASS 3/16"X1/2"
4	1	PC	PLATE BRASS 3/16"X1/2"
5	1	PC	PLATE BRASS 3/16"X1/2"
6	1	PC	PLATE BRASS 3/16"X1/2"
7	1	PC	PLATE BRASS 3/16"X1/2"
8	1	PC	PLATE BRASS 3/16"X1/2"
9	1	PC	PLATE BRASS 3/16"X1/2"
10	1	PC	PLATE BRASS 3/16"X1/2"
11	1	PC	PLATE BRASS 3/16"X1/2"
12	1	PC	PLATE BRASS 3/16"X1/2"
13	1	PC	PLATE BRASS 3/16"X1/2"
14	1	PC	PLATE BRASS 3/16"X1/2"
15	1	PC	PLATE BRASS 3/16"X1/2"
16	1	PC	PLATE BRASS 3/16"X1/2"
17	1	PC	PLATE BRASS 3/16"X1/2"
18	1	PC	PLATE BRASS 3/16"X1/2"
19	1	PC	PLATE BRASS 3/16"X1/2"
20	1	PC	PLATE BRASS 3/16"X1/2"
21	1	PC	PLATE BRASS 3/16"X1/2"
22	1	PC	PLATE BRASS 3/16"X1/2"
23	1	PC	PLATE BRASS 3/16"X1/2"
24	1	PC	PLATE BRASS 3/16"X1/2"
25	1	PC	PLATE BRASS 3/16"X1/2"
26	1	PC	PLATE BRASS 3/16"X1/2"
27	1	PC	PLATE BRASS 3/16"X1/2"
28	1	PC	PLATE BRASS 3/16"X1/2"
29	1	PC	PLATE BRASS 3/16"X1/2"
30	1	PC	PLATE BRASS 3/16"X1/2"
31	1	PC	PLATE BRASS 3/16"X1/2"
32	1	PC	PLATE BRASS 3/16"X1/2"
33	1	PC	PLATE BRASS 3/16"X1/2"
34	1	PC	PLATE BRASS 3/16"X1/2"
35	1	PC	PLATE BRASS 3/16"X1/2"
36	1	PC	PLATE BRASS 3/16"X1/2"
37	1	PC	PLATE BRASS 3/16"X1/2"
38	1	PC	PLATE BRASS 3/16"X1/2"
39	1	PC	PLATE BRASS 3/16"X1/2"
40	1	PC	PLATE BRASS 3/16"X1/2"
41	1	PC	PLATE BRASS 3/16"X1/2"
42	1	PC	PLATE BRASS 3/16"X1/2"
43	1	PC	PLATE BRASS 3/16"X1/2"
44	1	PC	PLATE BRASS 3/16"X1/2"
45	1	PC	PLATE BRASS 3/16"X1/2"
46	1	PC	PLATE BRASS 3/16"X1/2"
47	1	PC	PLATE BRASS 3/16"X1/2"
48	1	PC	PLATE BRASS 3/16"X1/2"
49	1	PC	PLATE BRASS 3/16"X1/2"
50	1	PC	PLATE BRASS 3/16"X1/2"
51	1	PC	PLATE BRASS 3/16"X1/2"
52	1	PC	PLATE BRASS 3/16"X1/2"
53	1	PC	PLATE BRASS 3/16"X1/2"
54	1	PC	PLATE BRASS 3/16"X1/2"
55	1	PC	PLATE BRASS 3/16"X1/2"
56	1	PC	PLATE BRASS 3/16"X1/2"
57	1	PC	PLATE BRASS 3/16"X1/2"
58	1	PC	PLATE BRASS 3/16"X1/2"
59	1	PC	PLATE BRASS 3/16"X1/2"
60	1	PC	PLATE BRASS 3/16"X1/2"
61	1	PC	PLATE BRASS 3/16"X1/2"
62	1	PC	PLATE BRASS 3/16"X1/2"
63	1	PC	PLATE BRASS 3/16"X1/2"
64	1	PC	PLATE BRASS 3/16"X1/2"
65	1	PC	PLATE BRASS 3/16"X1/2"
66	1	PC	PLATE BRASS 3/16"X1/2"
67	1	PC	PLATE BRASS 3/16"X1/2"
68	1	PC	PLATE BRASS 3/16"X1/2"
69	1	PC	PLATE BRASS 3/16"X1/2"
70	1	PC	PLATE BRASS 3/16"X1/2"
71	1	PC	PLATE BRASS 3/16"X1/2"
72	1	PC	PLATE BRASS 3/16"X1/2"
73	1	PC	PLATE BRASS 3/16"X1/2"
74	1	PC	PLATE BRASS 3/16"X1/2"
75	1	PC	PLATE BRASS 3/16"X1/2"
76	1	PC	PLATE BRASS 3/16"X1/2"
77	1	PC	PLATE BRASS 3/16"X1/2"
78	1	PC	PLATE BRASS 3/16"X1/2"
79	1	PC	PLATE BRASS 3/16"X1/2"
80	1	PC	PLATE BRASS 3/16"X1/2"
81	1	PC	PLATE BRASS 3/16"X1/2"
82	1	PC	PLATE BRASS 3/16"X1/2"
83	1	PC	PLATE BRASS 3/16"X1/2"
84	1	PC	PLATE BRASS 3/16"X1/2"
85	1	PC	PLATE BRASS 3/16"X1/2"
86	1	PC	PLATE BRASS 3/16"X1/2"
87	1	PC	PLATE BRASS 3/16"X1/2"
88	1	PC	PLATE BRASS 3/16"X1/2"
89	1	PC	PLATE BRASS 3/16"X1/2"
90	1	PC	PLATE BRASS 3/16"X1/2"
91	1	PC	PLATE BRASS 3/16"X1/2"
92	1	PC	PLATE BRASS 3/16"X1/2"
93	1	PC	PLATE BRASS 3/16"X1/2"
94	1	PC	PLATE BRASS 3/16"X1/2"
95	1	PC	PLATE BRASS 3/16"X1/2"
96	1	PC	PLATE BRASS 3/16"X1/2"
97	1	PC	PLATE BRASS 3/16"X1/2"
98	1	PC	PLATE BRASS 3/16"X1/2"
99	1	PC	PLATE BRASS 3/16"X1/2"
100	1	PC	PLATE BRASS 3/16"X1/2"

Note: - Please refer to the drawing for details.

Box Rear Switch

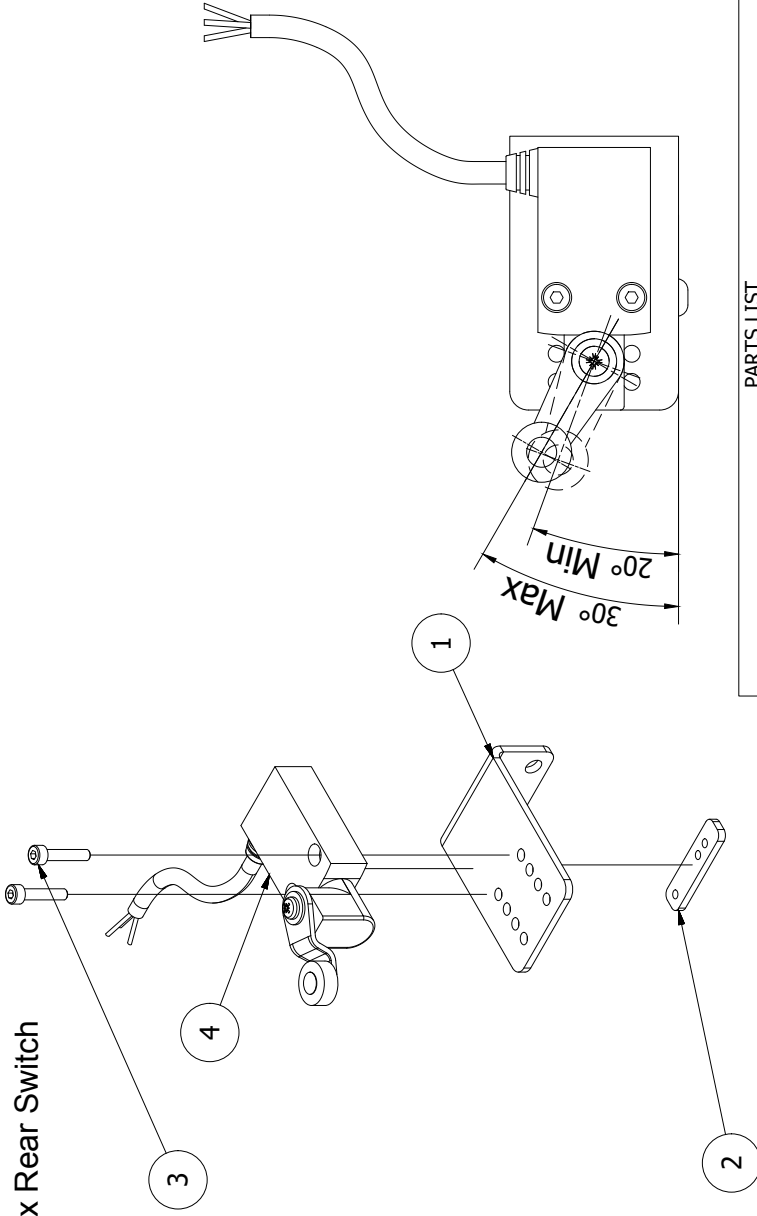

PARTS LIST			
ITEM	QTY	PART NUMBER	DESCRIPTION
1	1	ACCFABCAR50132	ACC Rear Switch Box Bracket
2	1	GNXAFABBOX60039	GNXA Box Lock Tapping Plate
3	2	FASBL/0402	M4 x 20 Socket Head Cap Screw
4	1	MN_550690	Switch XCMN2115L1

Note:- Fixings may vary

ω Box Lock Assembly Pre 2020

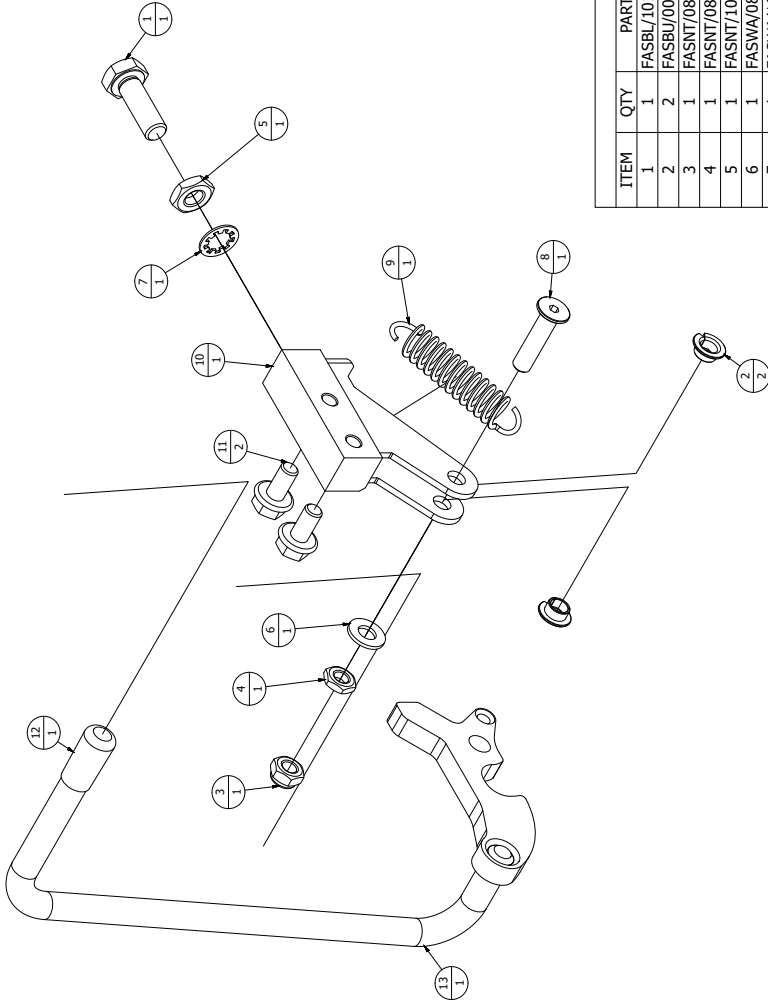

PARTS LIST

ITEM	QTY	PART NUMBER	DESCRIPTION
1	1	FASBL/1012	M10 X 30 Hex Head Set Screw
2	2	FASBU/0001	Flange Glacier Bush 10x8x5.5
3	1	FASNT/0801	M8 Nyloc Nut
4	1	FASNT/0802	M8 Half Nut
5	1	FASNT/1003	M10 Half Nut
6	1	FASWA/0801	M8 Plain Washer Form A
7	1	FASWA/1003	M10 Internal Star Washer
8	1	GXFABBOX40087	GX Box Lock Hook Pin
9	1	GXSPRBOX40084	GX Box lock Spring
10	1	ACCFABBOX50084	ACC Box Stop Lock Bracket
11	2	FASBL/0804	M8 x 16 CL 100 HT HEX S/L Z/P
12	1	ICONEC/0005	Flexi Cap FCWA-0095-025
13	1	ACCFABBOX50094	ACC Box lock Looped Handle

Note:- Fixings may vary

Box Lock Assembly

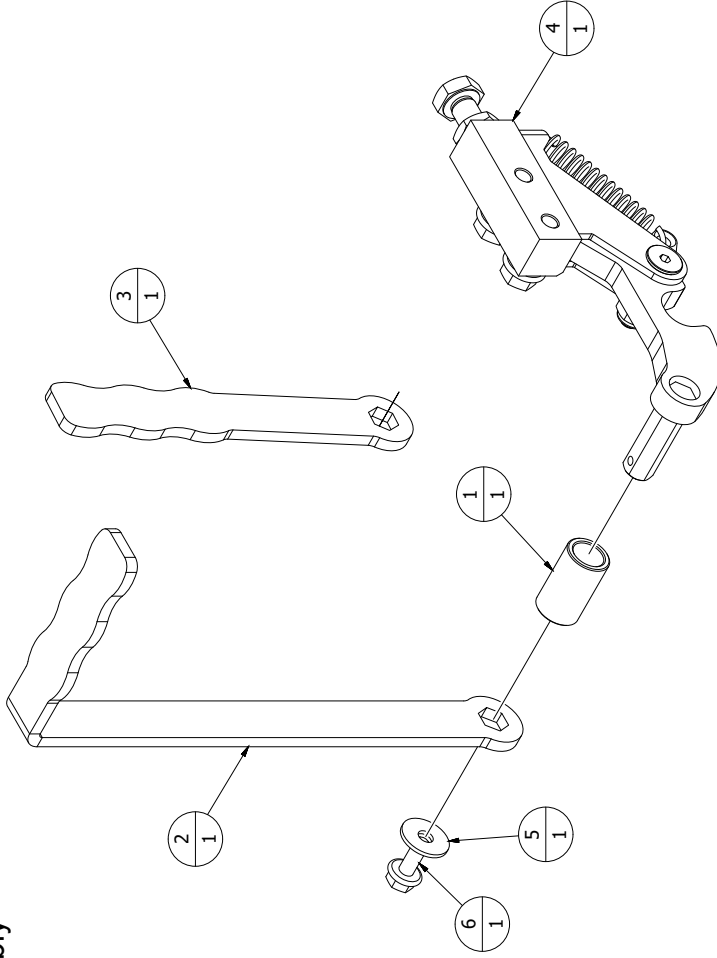

PARTS LIST			
ITEM	QTY	PART NUMBER	DESCRIPTION
1	1	MEGFABBOX120050	MEG Box Lock Sleeve
2	1	MEGFABBOX120049	MEG Box Lock Top Plate
3	1	MEGFABBOX120051	MEG Box Lock Plate Side
4	1	ASYACCBOS10-0136	ACC Box Lock STD Assembly
5	1	FASWA/0606	M6 Mud Guard Washer
6	1	FASBL/0601	M6 x .16 CL100 HT HEX S/L Z/P

Note: - Fixings may vary

5 Box Umbilical

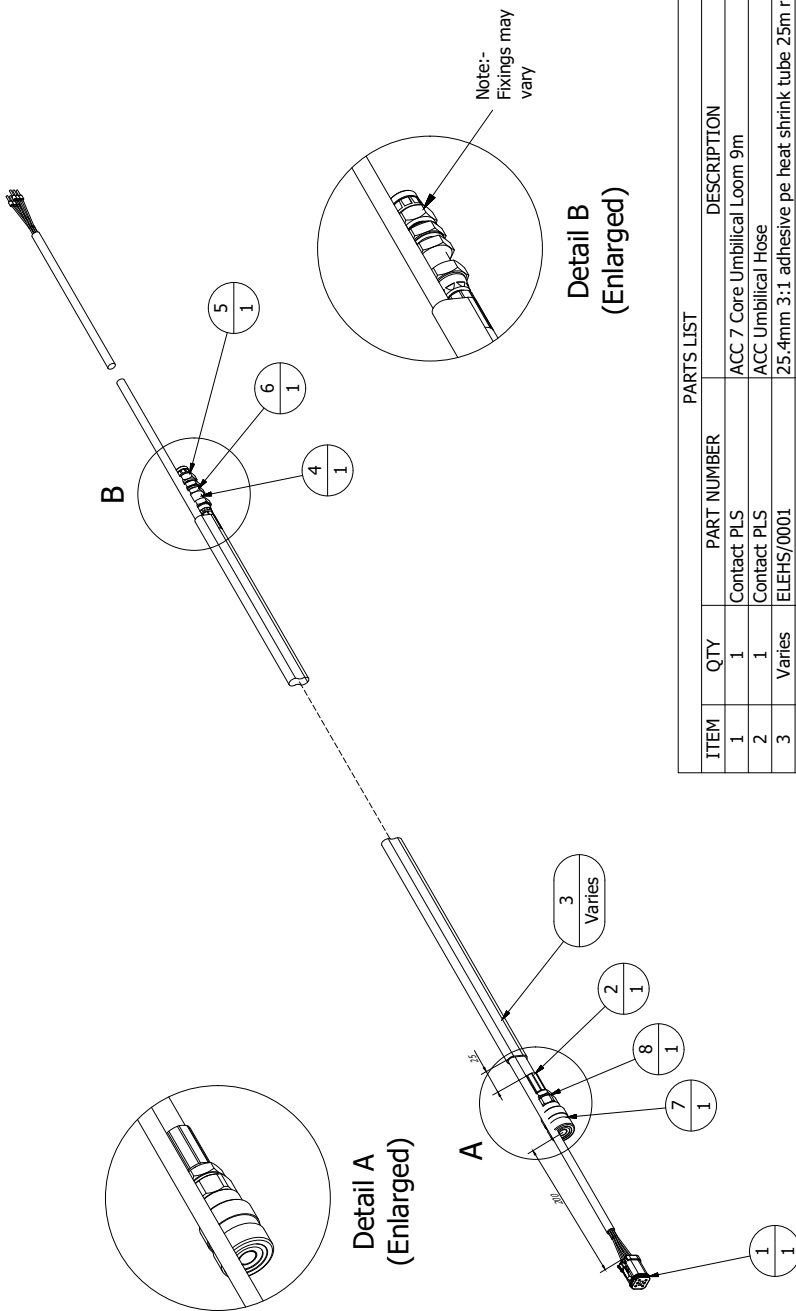

PARTS LIST		DESCRIPTION
ITEM	QTY	PART NUMBER
1	1	ACC 7 Core Umbilical Loom 9m
2	1	ACC Umbilical Hose
3	Varies	25.4mm 3:1 adhesive pe heat shrink tube 25m rolls
4	1	1/4 BSP Bulkhead MM (PLS1)
5	1	Cap 1/4 PLS7
6	1	1/4 BSP Locknut (PLS10)
7	1	HYDPR/0002
8	1	HYDWA/0001

Note:- Fixings may vary

Carriage Assembly

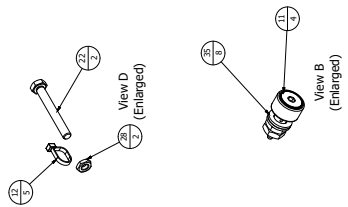
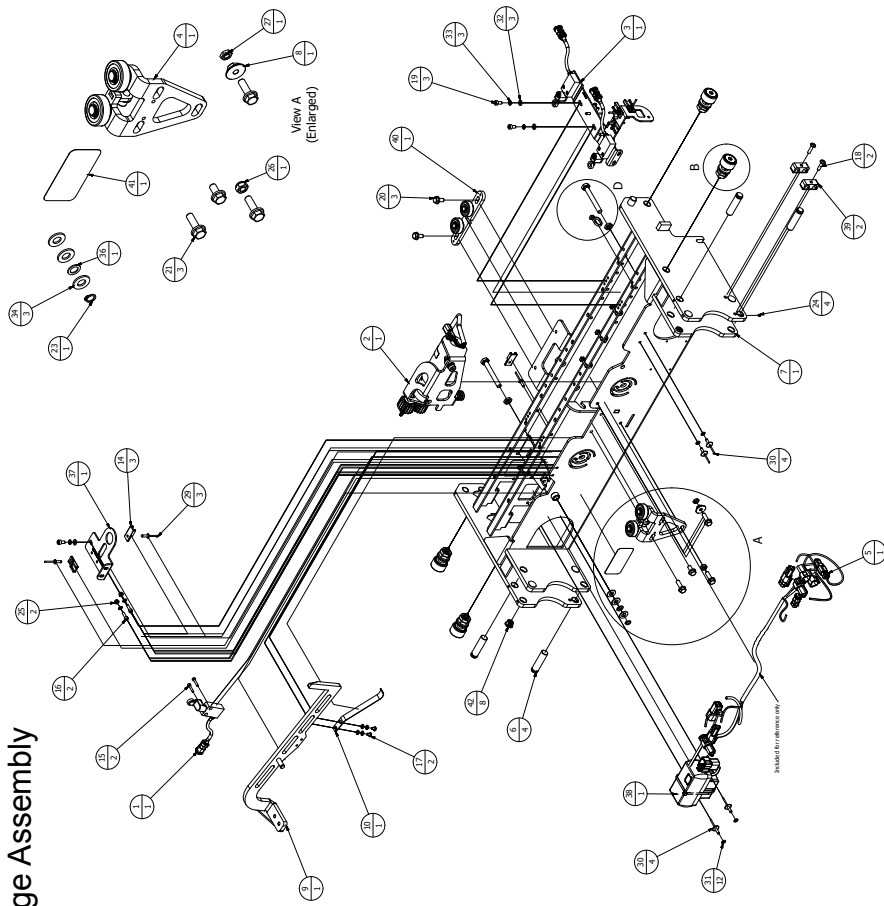

ITEM	QTY	PART NUMBER	DESCRIPTION
1	1	ACC55000	Base Switch (CONP) (S/L) (With Decoupl. Ring)
2	1	CONP.F.S.	Motor Assembly (With Decoupl. Ring & Assembly)
3	1	ASTVACCA55130227	ACC Front Centre Bearing Assembly
4	1	ACC55001	ACC Carriage Bearing Harness
5	1	ACC55002	ACC Carriage Spring
6	1	ACC55003	MIS Carriage
7	1	ACC55004	ACC Motor Support Base
8	1	ACC55005	ACC Carriage Lock and Spring
9	1	ACC55006	Cam Follow-up Straps (Single) (MFR 33) (S&K) (MEL)
10	1	ACC55007	CCM 10000
11	1	ACC55008	CCM 10002
12	20/100	CONV.10002	Standard EPA Marking 400A
13	1	ELEC.10002	Brush Attachment, Cap (2-6 way, Remov.)
14	3	FAST.105	M3 x 4.5 Socket Head Drive
15	2	FAST.105 B	M3 x 4.5 Socket Head Drive
16	2	FAST.105 B	M3 x 4.5 Socket Head Drive
17	2	FAST.105 B	M3 x 4.5 Socket Head Drive
18	2	FAST.105 B	M3 x 4.5 Socket Head Drive
19	2	FAST.105 B	M3 x 4.5 Socket Head Drive
20	3	FAST.105 B	M3 x 4.5 Socket Head Drive
21	3	FAST.105 B	M3 x 4.5 Socket Head Drive
22	3	FAST.105 B	M3 x 4.5 Socket Head Drive
23	1	FAST.1001	M3 x 4.5 Socket Head Drive
24	4	FAST.105 B	M3 x 4.5 Socket Head Drive
25	1	FAST.105 B	M3 x 4.5 Socket Head Drive
26	1	FAST.105 B	M3 x 4.5 Socket Head Drive
27	1	FAST.105 B	M3 x 4.5 Socket Head Drive
28	1	FAST.105 B	M3 x 4.5 Socket Head Drive
29	3	FAST.105 B	M3 x 4.5 Socket Head Drive
30	3	FAST.105 B	M3 x 4.5 Socket Head Drive
31	3	FAST.105 B	M3 x 4.5 Socket Head Drive
32	3	FAST.105 B	M3 x 4.5 Socket Head Drive
33	3	FAST.105 B	M3 x 4.5 Socket Head Drive
34	3	FAST.105 B	M3 x 4.5 Socket Head Drive
35	3	FAST.105 B	M3 x 4.5 Socket Head Drive
36	3	FAST.105 B	M3 x 4.5 Socket Head Drive
37	3	FAST.105 B	M3 x 4.5 Socket Head Drive
38	3	FAST.105 B	M3 x 4.5 Socket Head Drive
39	3	FAST.105 B	M3 x 4.5 Socket Head Drive
40	3	FAST.105 B	M3 x 4.5 Socket Head Drive
41	3	FAST.105 B	M3 x 4.5 Socket Head Drive
42	8	CONV.10227	Standard EPA Marking 400A

Note: Fitings may vary

➤ In / Out Motor Assembly

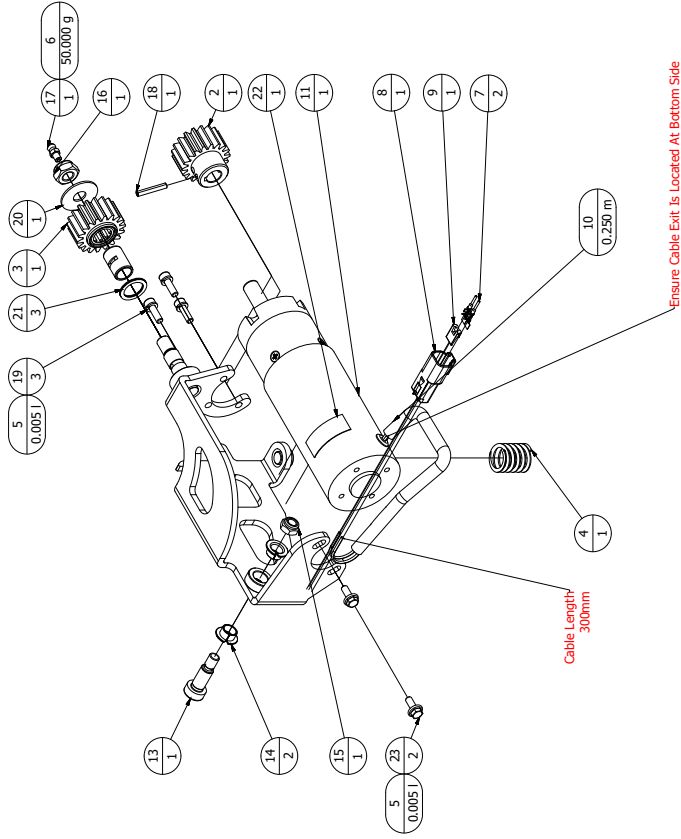

PARTS LIST			
ITEM	QTY	PART NUMBER	DESCRIPTION
1	1	ACCFBAR50133	ACC Carriage Motor Bracket
2	1	ACCFBAR50144	ACC Carriage Drive Gear 18T
3	1	ACCFBAR50145	ACC Rack Gear 18 Tooth
4	1	ACCSRCAR50146	ACC Carriage Motor Spring
5	0.005 l	ADTHR/0001	A1042 Threadlock Adhesive Permabond 50ml
6	50.000 g	CON07/0002	Spreared EPL2 Grease 400g
7	2	ELEDE/0001	Deuschel Resel Pins 1060-16-0122 (4000 p/roll) (D104-2P-CF02)
8	1	ELEDE/0003	AW2P (W2P) 2 WAY RECEPTACLE WEDGE Heat Shrink 9.5mm OD 60m Roll
9	1	ELEDE/0009	Parvelux Carriage Motor
10	0.250 m	ELEHS/0003	M5 x 16 Socket Head Capscrew
11	1	Contact PL5	Flange Glacier Bush 10x12x7
12	3	FASBL/0518	M10 Nyloc Nut
13	1	FASBL/9802	M5 Grease Nipple
14	2	FASBU/0003	Spiral Pin 4 x 24mm
15	1	FASNT/0801	M5 Spring Washer
16	1	FASOT/1001	M10 x 30 Repair Washer
17	1	FASOT/0501	M16 Shim Washer
18	1	FASPN/0401	WL98 LABEL LEGEND TESTED (PACK 350)
19	3	FASPN/0504	M5 X 12 Serrated Hex Head Screw
20	1	FASWA/1004	
21	3	FASWA/1604	
22	1	CONLB/0002	
23	2	FASBL/9502	

Note:- Fixings may vary

Front Centre Bearing and Rear Bearing

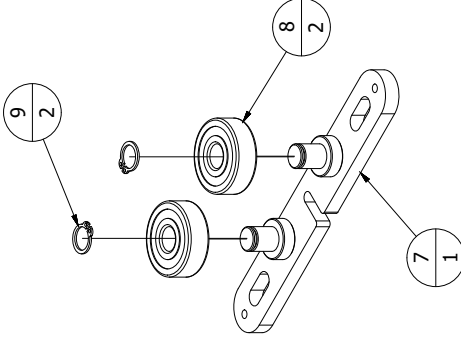
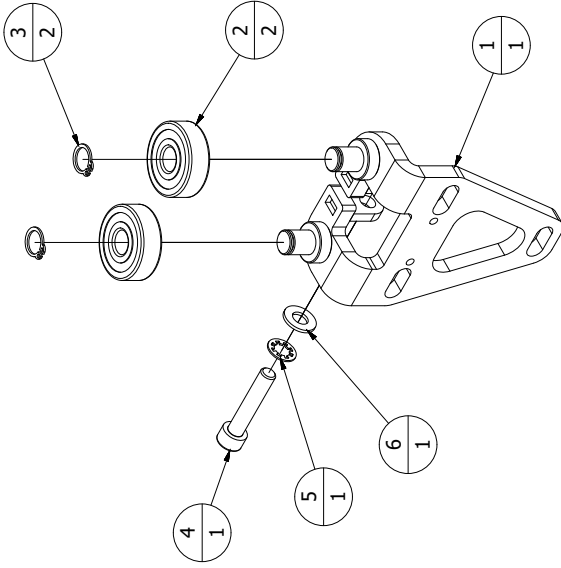

PARTS LIST - FRONT CENTRE BEARING	
ITEM QTY	PART NUMBER DESCRIPTION
1	ACCFABCAR50135 ACC Carriage Front Bearing BRKT
2	BEARN/0001 Front & Rear Centre Bearing 6301-2RS1
3	FASCC/1201 M12 External Circlip
4	FASBL/0803 M8 x 40 Socket Head Capscrew
5	FASWA/0803 M8 Internal Star Washer
6	FASWA/0801 M8 Plain Washer Form A

Note:- Fixings may vary

PARTS LIST - REAR BEARING	
ITEM QTY	PART NUMBER DESCRIPTION
7	ACCFABCAR50142 ACC Rear Bearing BRKT
8	BEARN/0001 Front & Rear Centre Bearing 6301-2RS1
9	FASCC/1201 M12 External Circlip

Carriage Switch Bracket Assembly

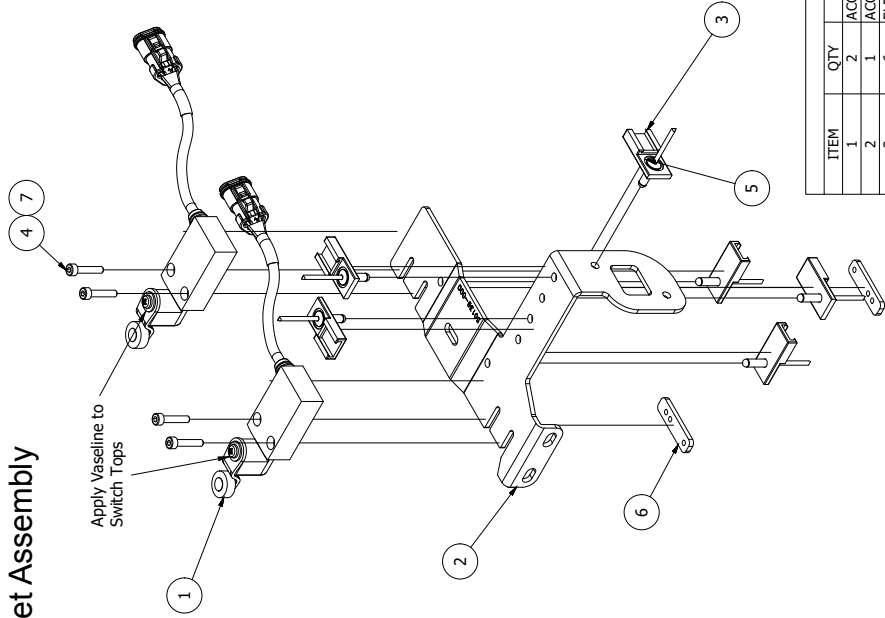

PARTS LIST			
ITEM	QTY	PART NUMBER	DESCRIPTION
1	2	ACC50690	Blue Switch (XCMN2115L1) With Deutsch Plug
2	1	ACCFABCAR50139-000	ACC Carriage Switch Bracket
3	6	ELECT/0002	Deutsch Attachment Clips (2-6 way Female)
4	4	FASBI/0402	M4 x 20 Socket Head Cap Screw
5	6	FASRV/0001	4.8 x 1.6 Dome Head Rivet
6	2	GNXAFABBDX60039	GNXA Box Lock Tapping Plate
7	0.005 l	ADTHR/0001	A1042 Threadlock Adhesive Permabond 50ml

Note:- Fixings may vary

Carriage Hydraulics

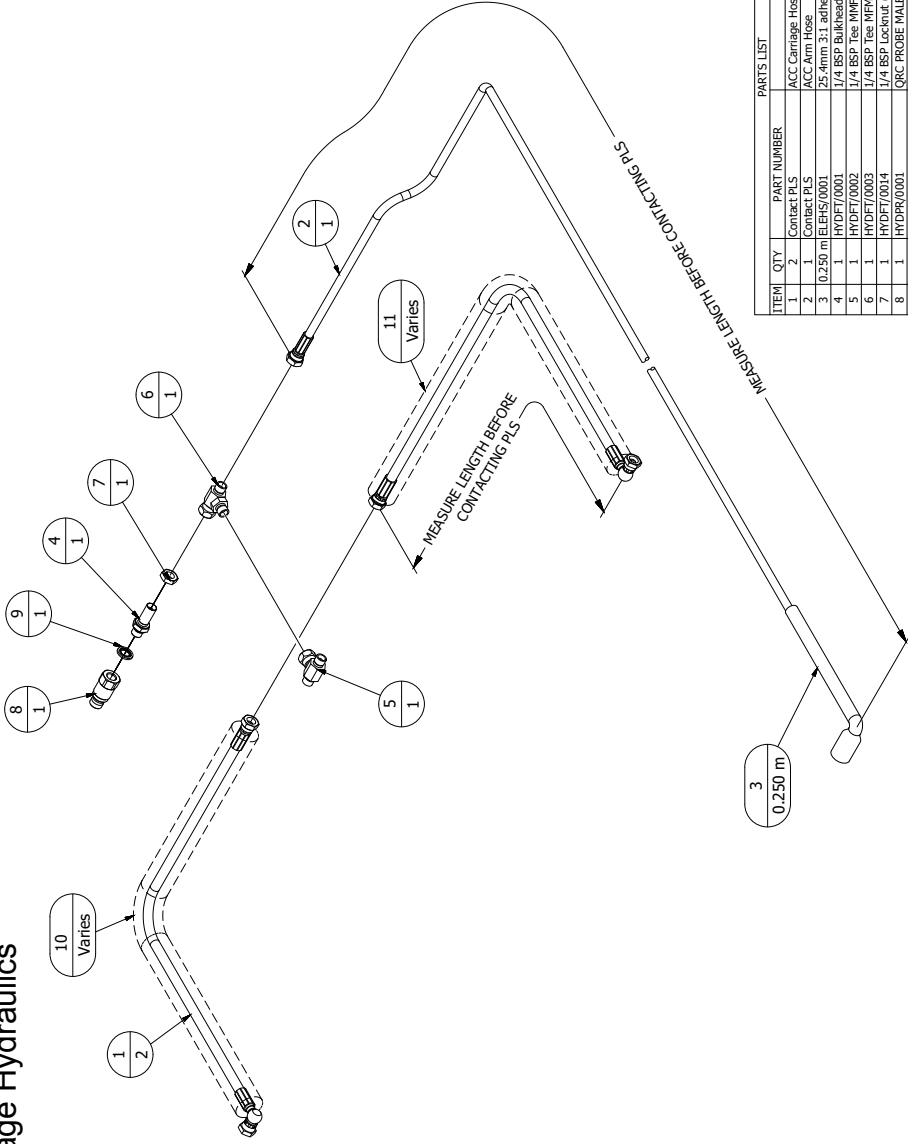

ITEM	QTY	PART NUMBER	DESCRIPTION
1	2	Contact PLS	ACC Carriage Hose
2	1	Contact PLS	ACC Arm Hose
3	0.250 m	ELH5/0001	25.4mm 3:1 adhesive pe heat shrink tube 25m rolls
4	1	HYDF1/0001	1/4 BSP Bulkhead MFM (PLS1)
5	1	HYDF1/0002	1/4 BSP Tee MFM (PLS12)
6	1	HYDF1/0003	1/4 BSP Tee MFM
7	1	HYDF1/0014	1/4 BSP Locknut (PLS10)
8	1	HYDR/0001	QRC PROBE MALE (20x0.00045)
9	1	HYDWA/0001	1/4 BSP Dowty Seal (Bonded Washer)
10	Varies	HYDHOS1PRS-22	22mm Anti Burst Sleeve
11	Varies	HYDHOS1PRS-22	22mm Anti Burst Sleeve

Note:- Fittings may vary

H Handrail 'H' Assembly

Throw "Out" Handrail is Optional and NOT fitted as standard

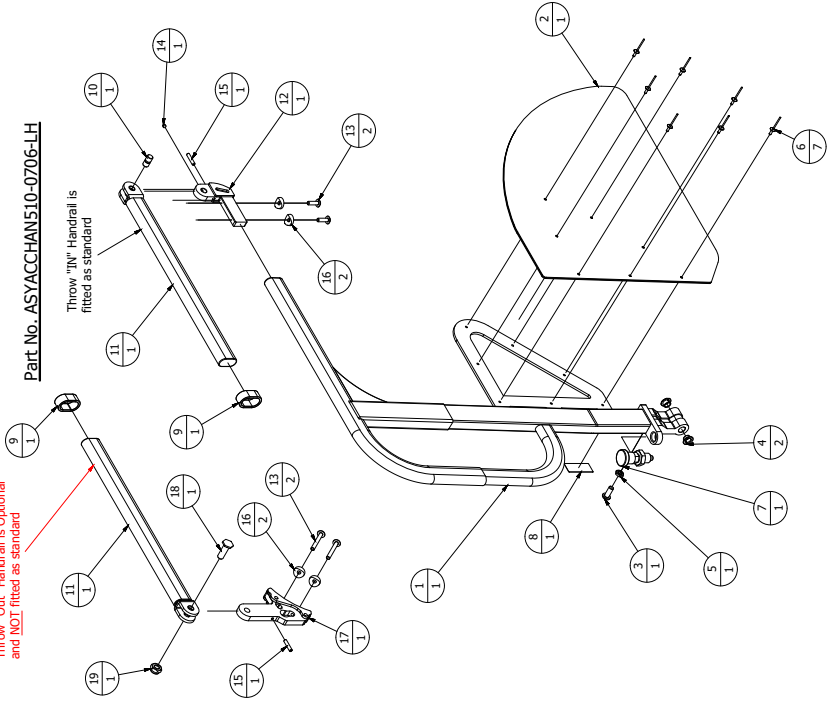

Part No. ASYACCHAN510-0706-LH

Throw "IN" Handrail is fitted as standard

Part No. ASYACCHAN510-0706-RH

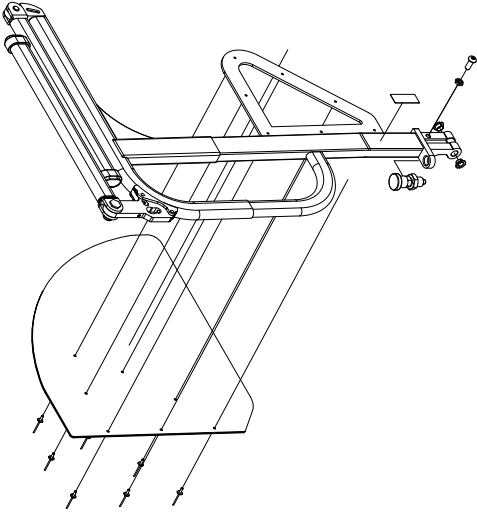

ITEM	QTY	PART NUMBER	DESCRIPTION
1	1	ACCFABHAN50703-LH/RH	ACC Handrail Frame 'H' LH/RH
2	1	ACCPHIANH50781	ACC Handrail Guard 'H'
3	1	FASBL/0801	M8 x 20 Socket Head Dome
4	2	FASBL/0803	Flange Glycer Bush 10x12x7
5	1	FASN7/0802	M8 Half Nut
6	7	FASRV/0808-BLK	3.2 x 10 Large Flange Head Rivet Black
7	1	GN717-8-M16x1.5-BK-NI	S/Steel M16 Index Plunger & Nut
8	1	CONLE/0012	Pull To Unlock Sticker
9	2	ACCPHIANH50730	ACC Handrail Rubber Band
10	1	ACCFABHAN50706	ACC Handrail Throw Over Pin
11	2	ACCFABHAN50786-5	ACC Handrail Throw Over
12	1	ACCFABHAN50786-5	ACC Handrail Throw Over
13	4	FASBL/0624	M5 x 20 Single Flange Over Head A2
14	1	FASGS/0501	M5 x 6.5 Hex Flange Cap Screw DIN 914
15	2	FASGS/0503	M5 x 25mm Cap Prot Grub Screw BZP
16	4	ESTIME-WSH-SADDLE	M6 Saddle WSH 102.0200.000.01
17	1	ACCFABHAN50746	ACC Handrail Throw Over Base
18	1	FASBL/1016	M10 x 30 Hex Head Set Screw Turned Down
19	1	FASN7/1001	M10 Nyloc Nut

Note:- Fixings may vary

Single Throw In Handrail

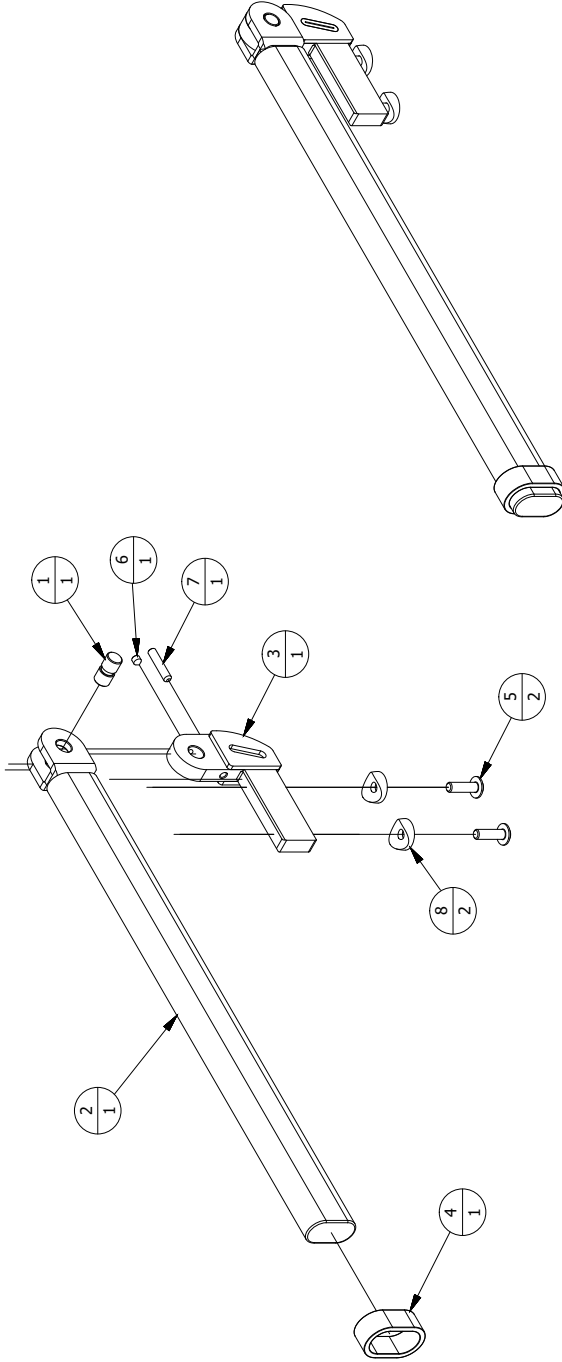

PARTS LIST		
ITEM	QTY	PART NUMBER DESCRIPTION
1	1	ACCFABHAN50706 ACC Handrail Throw Over Pin
2	1	ACCFABHAN50747 ACC Handrail Throw Over
3	1	ACCFABHAN50786-S ACC Rear Single Throw Over
4	1	ACCPLAHAN50730 ACC Handrail Rubber Band
5	2	FASBL/0624 M6 x 20 Socket Flange Dome Head A2
6	1	FASGS/0501 M5 x 6mm Cup Point Grub Screw DIN 914
7	1	FASGS/0503 M5 x 25mm Cup Point Grub Screw BZP
8	2	FSTMG-WSH-SADDLE M6 Saddle WSH...102.0200.000.01

Note:- Fixings may vary

13 Single Throw Out Handrail

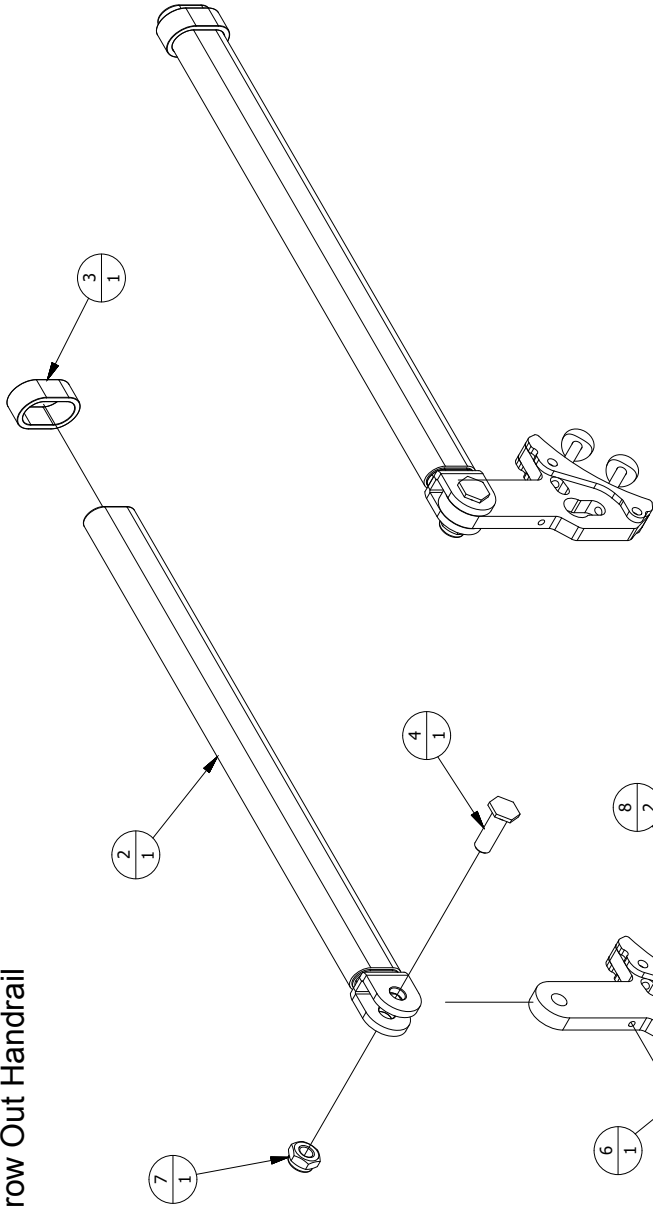

PARTS LIST			
ITEM	QTY	PART NUMBER	DESCRIPTION
1	1	Contact PLS	ACC Handrail Throw Over Base
2	1	ACCFABHAN50747	ACC Handrail Throw Over
3	1	ACCFABHAN50730	ACC Handrail Rubber Band
4	1	FASBL/1016	M10 x 30 Hex Head Set Screw Turned Down
5	2	FASBL/9618	M6 x 50 Socket Flange Dome Head A2
6	1	FASGS/0503	M5 x 25mm Cup Point Grub Screw BZP
7	1	FASNT/1001	M10 Nyloc Nut
8	2	FSTM6-WSH-SADDLE	M6 Saddle WSH_102.0200.000.01

Note:- Fixings may vary

Lower Left Arm

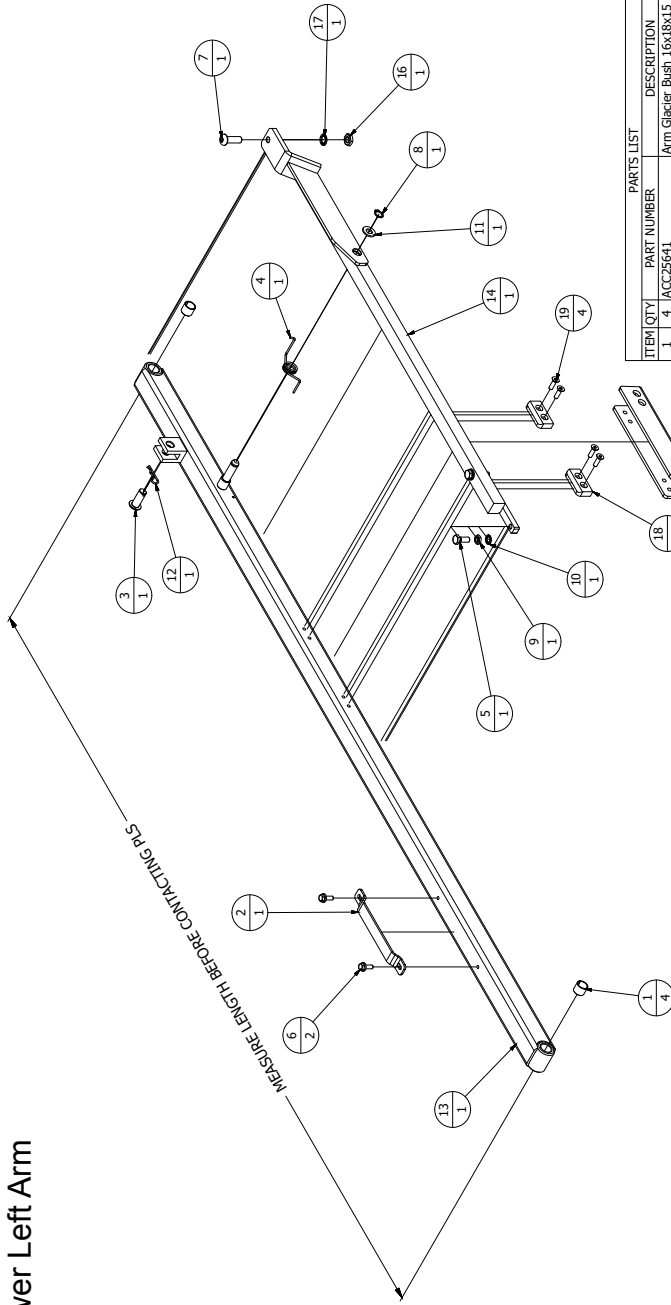

PARTS LIST			
ITEM QTY	PART NUMBER	DESCRIPTION	
1	4	ACC25641	Arm Glacier Bush 16x18x15
2	1	ACCFA8ARM50384	ACC Arm Top Hat
3	1	ACCFA8ARM50393	ACC Cylinder Clevis Pin
4	1	ACCSPRARM50298-LH	ACC Arm Rocker Spring LH
5	1	FASBL/0822	M6 x 20 Hex Head S&B Screw
6	2	FASBL/1014	M6 x 16 CLL100 HT HEX S/L Z/P
7	1	FASBL/1014	M10 x 30 Socket Head Dome
8	1	FASCC/1201	M12 External O-Ring
9	1	FASNT/0802	M8 Half Nut
10	1	FASWA/0803	M8 Internal Star Washer
11	1	FASWA/1091	M10 Nylon Washer Form A
12	1	FLA95581	2.0 X 9-12 57/5T R Clip (per 100)
13	1	Contact PLS	MEG Lower Left Arm
14	1	Contact PLS	MEG LH Arm Rocker
15	1	Contact PLS	ACC Rocker Support
16	1	FASNT/1003	M10 Half Nut
17	1	FASWA/1003	M10 Internal Star Washer
18	2	ACC27198	ACC Rocker Support Bracket Pad
19	4	FASBL/0620	M6 x 20 Socket Head CSK A2

Note:- Fixings may vary

15 Lower Right Arm

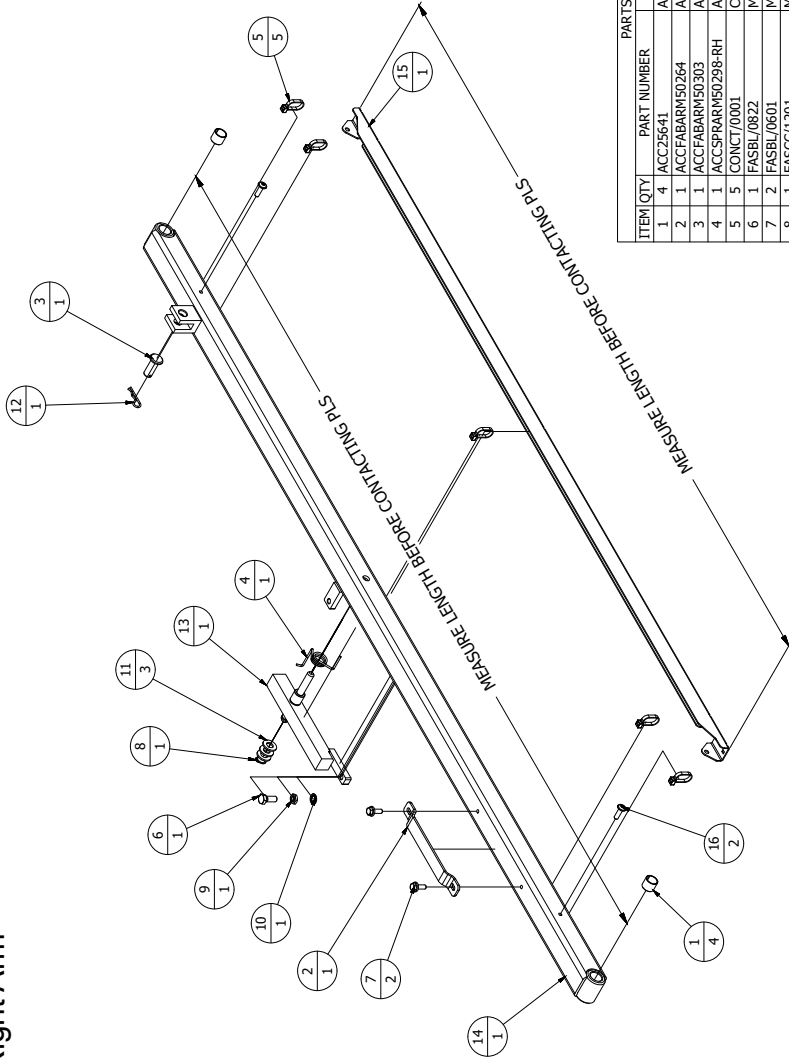

PARTS LIST		
ITEM	QTY	DESCRIPTION
1	4	ACC25641
2	1	ACC FARM50264
3	1	ACC FARM50303
4	1	ACC SPRARM50298-RH
5	5	CONCT/0001
6	1	FASBL/0822
7	2	FASBL/0601
8	1	FASCC/1201
9	1	FASNT/0802
10	1	FASWA/0803
11	3	FASWA/1091
12	1	ELA35581
13	1	Contact PLS
14	1	Contact PLS
15	1	Contact PLS
16	2	FASBL/0624

Note:- Fixings may vary

Upper Left Arm

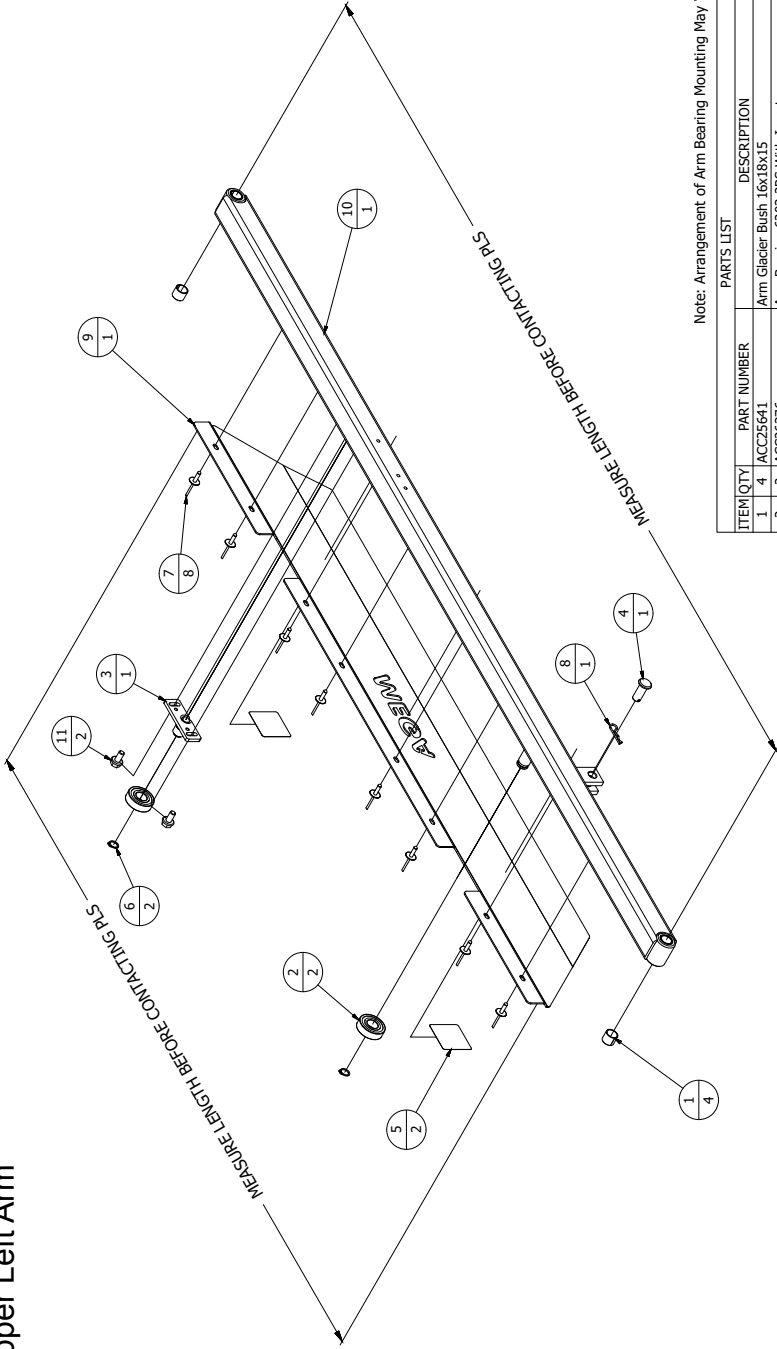

Note: Arrangement of Arm Bearing Mounting May Vary

PARTS LIST		
ITEM/ QTY	PART NUMBER	DESCRIPTION
1	ACC25641	Arm Glacier Bush 16x18x15
2	ACC26376	Arm Bearing 6203 ZRS With Insert
3	ACCFABARM50268	ACC Arm Bearing Carrier
4	ACCFABARM50303	ACC Cylinder Clevis Pin
5	ACCPRIREFVELTAPE-Y	YELLOW REFLECTIVE PRISMATIC TAPE 50 x 50 x 50m
6	FASCCJ1201	M12 External Circlip
7	FASRV/0014	4.8 x 16 Large Flange Head Rivet
8	FLA35581	2.0 X 9-12 ST/ST R Clip (per 100)
9	Contact PLS	MEG Arm Guard
10	Contact PLS	MEG Upper Left Arm
11	FASBL/0804	M8 x 16 CL 100 HT HEX S/L Z/P

BOTH OLD AND NEW METHODS OF ARM BEARING ARRANGEMENTS SHOWN

Note:- Fixings may vary

17 Upper Right Arm

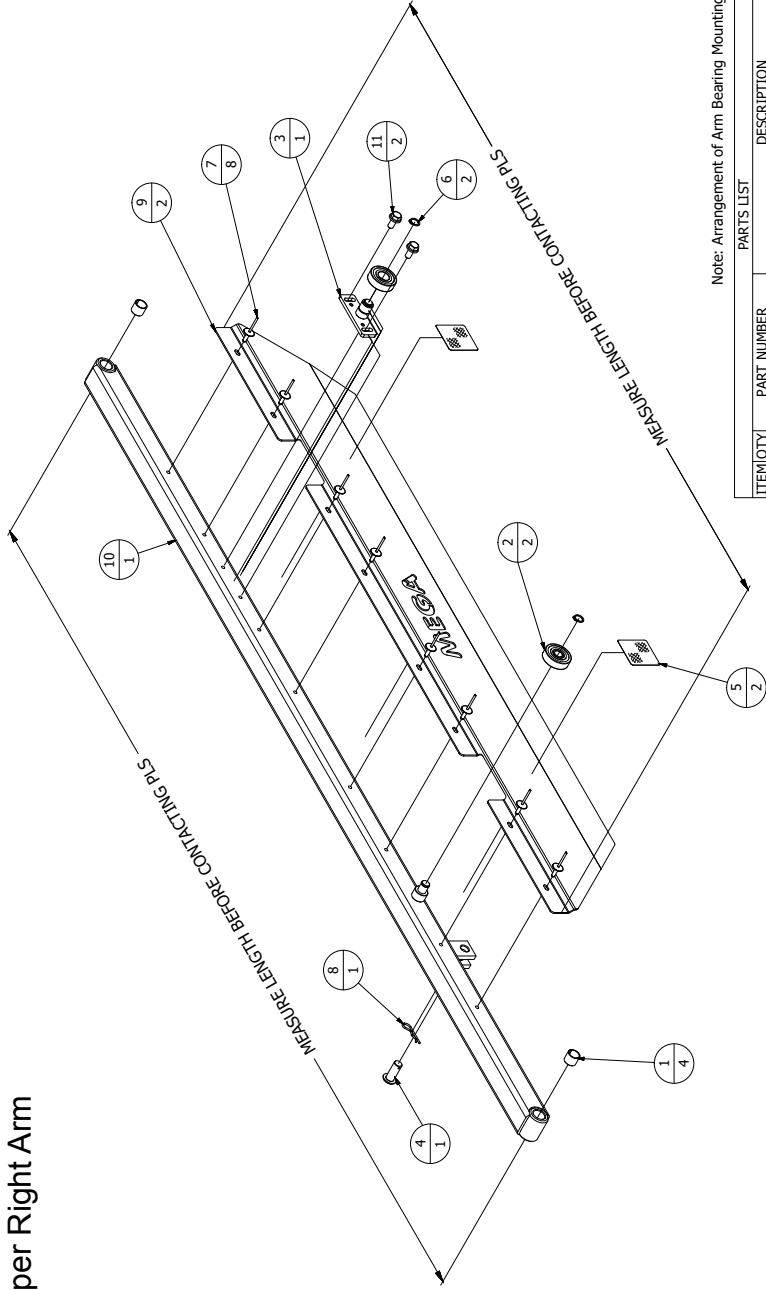

Note: Arrangement of Arm Bearing Mounting May Vary

ITEM/QTY	PART NUMBER	DESCRIPTION
1	4	ACC25641
1	4	ACC25641
2	2	ACC26376
3	1	ACCFABARM50268
4	1	ACCFABARM50303
5	2	ACCFRISREFYELTAPE-Y
6	2	FASCC/L201
7	8	FASRV/0014
8	1	FLA3581
9	2	Contact PLS
10	1	Contact PLS
11	2	FASBL/0804

BOTH OLD AND NEW METHODS OF ARM BEARING ARRANGEMENTS SHOWN

Note:- Fixings may vary

Arm Cylinders

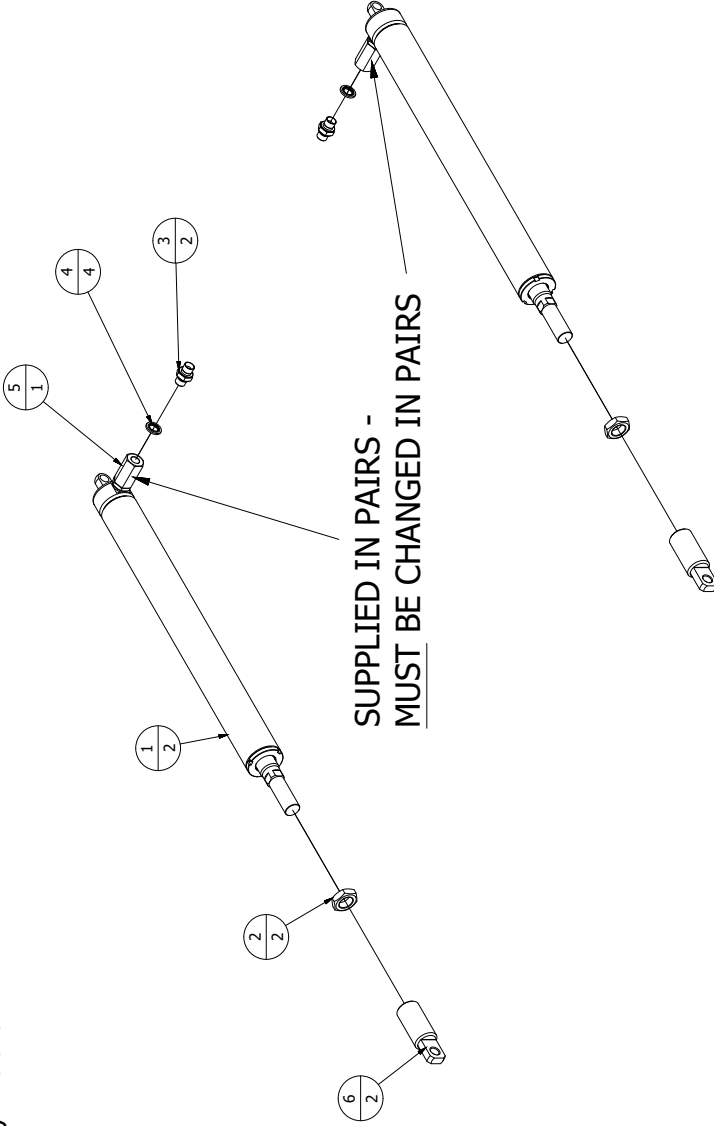

PARTS LIST		DESCRIPTION
ITEM	QTY	PART NUMBER
1	2	Contact PLS
2	2	Arm Cylinder Mega
3	2	M20 x 1.5 Half Nut
4	4	1/4 BSP Male Male Straight
5	1	1/4 BSP Dowty Seal (Bonded Washer)
6	2	PC Valves-100420-Crash Valve New Type (Pair)
		MEG Cylinder Rod End

Note:- Fixings may vary

19 Arm Brace

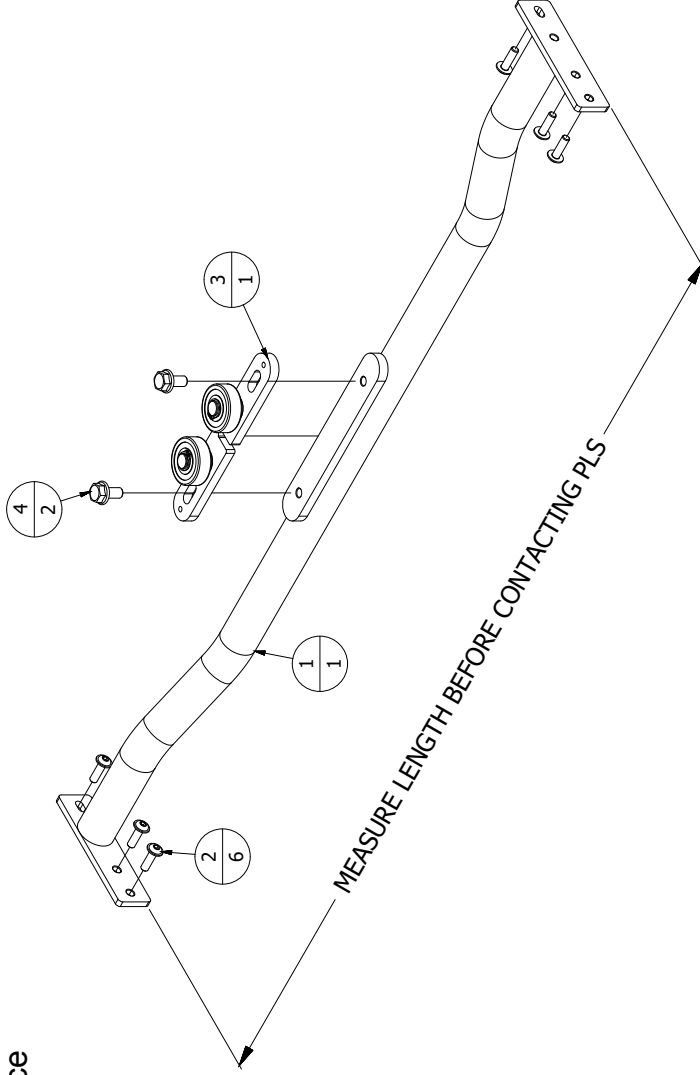

PARTS LIST			
ITEM	QTY	PART NUMBER	DESCRIPTION
1	1	Contact PLS	MEG Arm Stabilizer
2	6	FASBL/0624	M6 x 20 Socket Flange Dome Head A2
3	1	CARACCASY510-0230	ACC Rear Bearing Assembly
4	2	FASBL/0804	M8 x 16 CL 100 HT HEX S/L Z/P

Note:- Fixings may vary

Bridge Plate Assembly

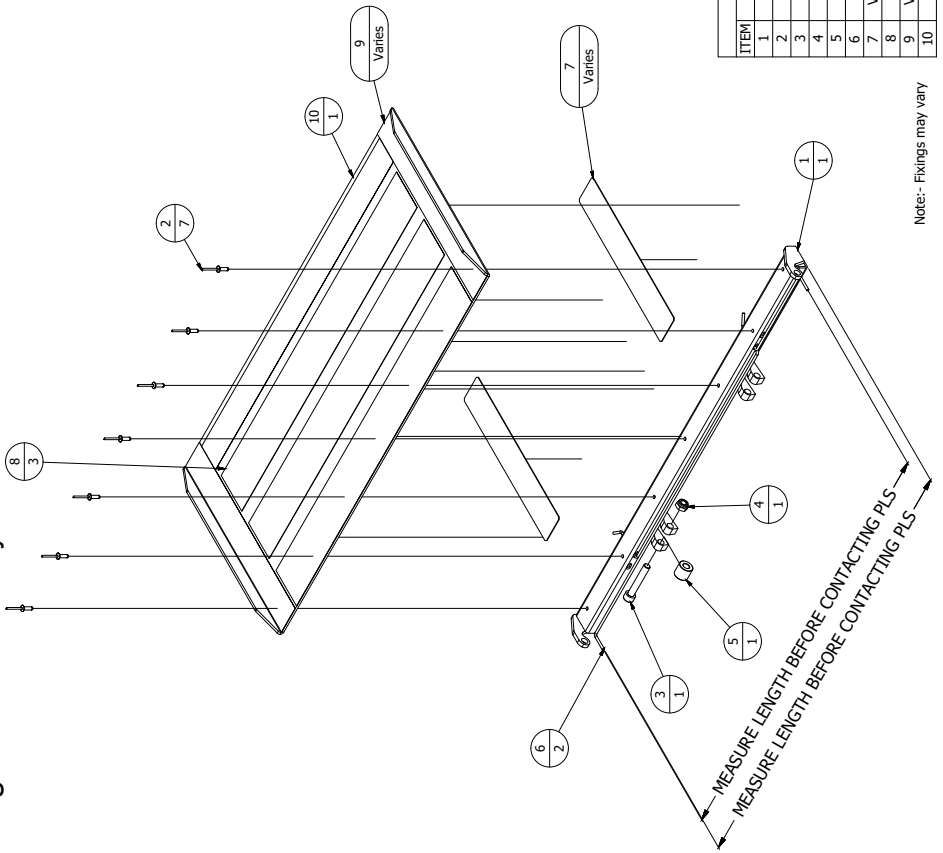

PARTS LIST			
ITEM	QTY	PART NUMBER	DESCRIPTION
1	1	Contact PLS	ACC Bridge Plate Hinge Lite
2	7	FASRV/0001	4.8 x 16 Dome Head Rivet
3	1	FASBL/1005	M10 x 60 Socket Head Capscrew
4	1	FASNT/1001	M10 Nivloc Nut
5	1	ACCFABRP50530-22	ACC Bridge Plate Roller 22
6	2	Contact PLS	ACC Bridge Plate Torsion Bar
7	Varies	Contact PLS	BT60-T4005-050-G1 Tribo Tape 50mm wide - 50 Mtr Roll
8	3	ACCCLTBLK75-6-40	Black Clearing 75 x 640mm
9	Varies	Contact PLS	50mm Yellow Clearing Roll
10	1	Contact PLS	MEG Pla-xtons Bridge Plate Ally

Platform Alloy

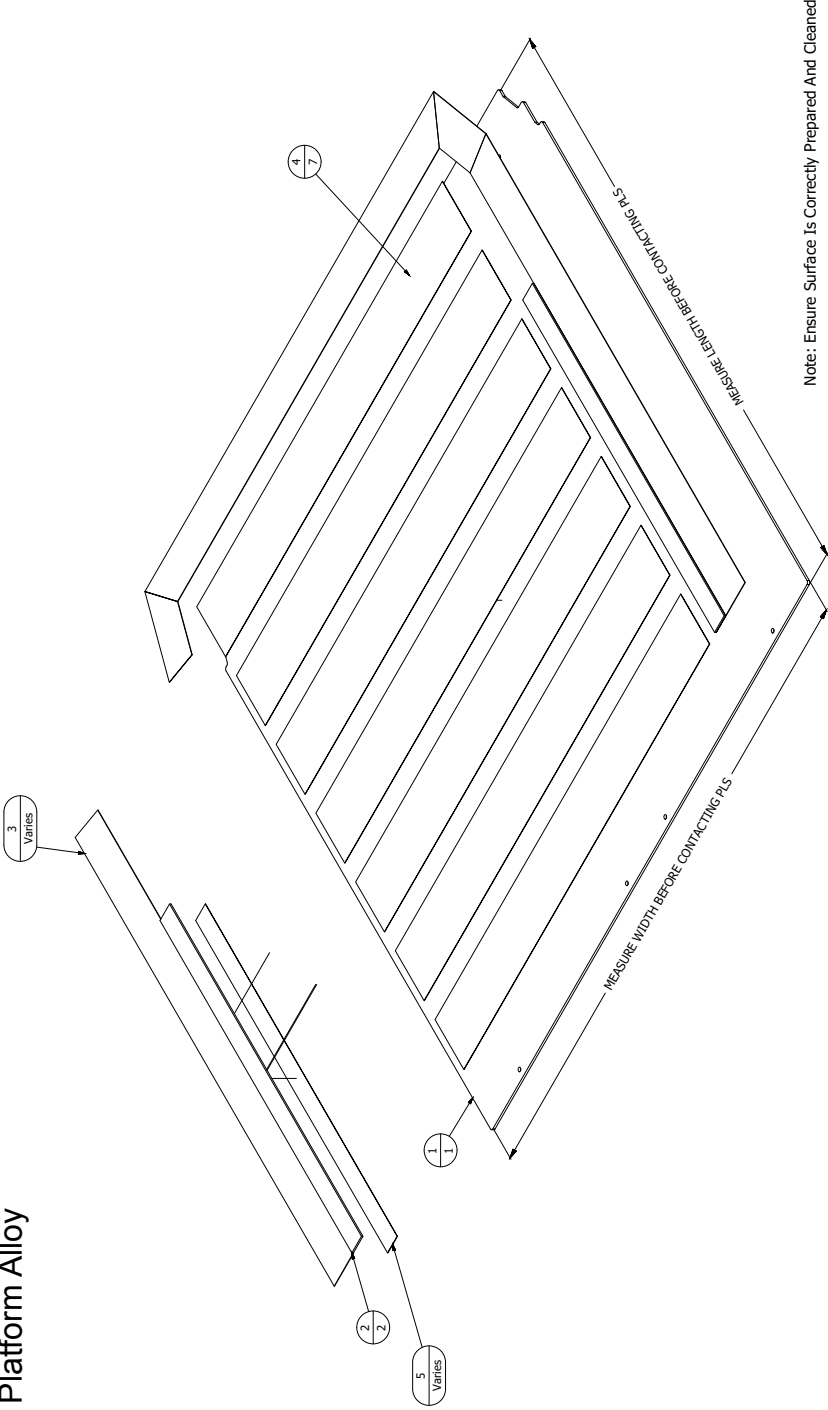

Note: Ensure Surface Is Correctly Prepared And Cleaned

PARTS LIST			
ITEM	QTY	PART NUMBER	DESCRIPTION
1	1	ACC Platform Ally	ACC Platform Ally
2	2	ACC25742/A	Nylon Wear Strip 500 x 25 x 2mm
3	Varies	Contact PLS	50mm Yellow Clearing Roll 18 .3m
4	7	ACCCLBLK75-640	Black Clearing 75 x 640mm
5	Varies	Contact PLS	25 mm Double Sided Tape / Glue

Note:- Fixings may vary

23 Platform Extension

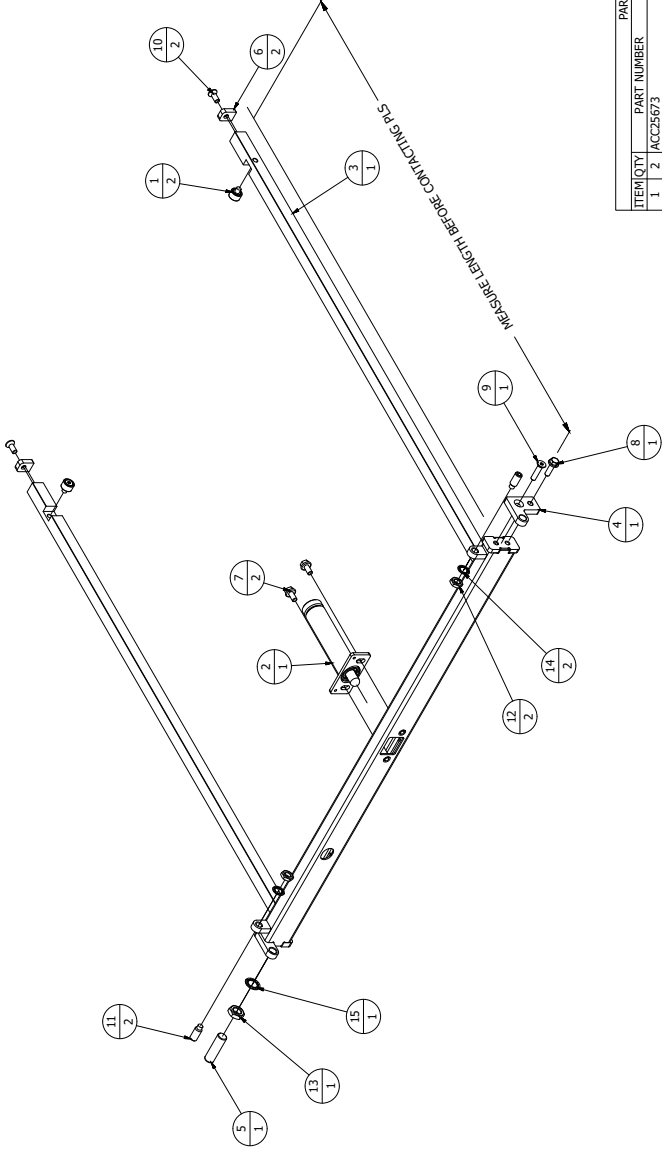

PARTS LIST		
ITEM QTY	PART NUMBER	DESCRIPTION
1	ACC25673	Extension Cam Follower KRI99PX (CF8UU)
2	ACC26295	MX Hydraulic Ramp Cylinder
3	Contact PLS	ACC Extension Frame Lite
4	ACCFABEXTS0431--RH	ACC Extension Ramp Hinge Plate RH
5	ACCFABEXTS0433	ACC Extension Lock Pin
6	ACCFABEXTS0434--MS	ACC Platform Extension Stop Mild Steel
7	PASBL/0804	M8 x 25 CL100 HT HEX S/L Z/P
8	PASBL/0805	M8 x 35 Socket Head CSK
9	PASBL/0806	M8 x 20 Socket Head CSK
10	PASBL/0823	M12 x 30 Stainless Steel Socket Set
11	PASNT/1209	M12 Hair Nut
12	PASNT/1603	M16 Hair Nut
13	PASWAY/1203	M12 Internal Star Washer
14	PASWAY/1603	M16 Internal Star Washer
15	PASWAY/1603	M16 Internal Star Washer

Note:- Fixings may vary

Extension Alloy

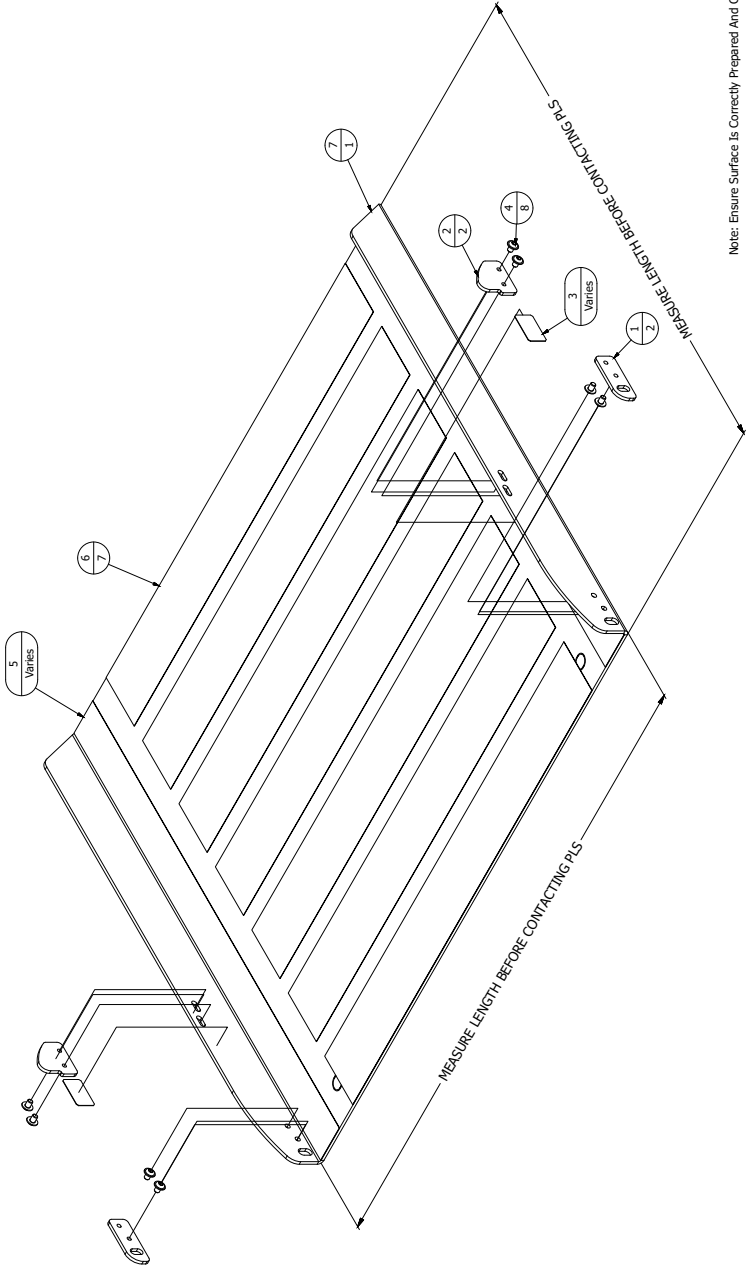

Note: Ensure Surface Is Correctly Prepared And Cleaned

PARTS LIST			
ITEM	QTY	PART NUMBER	DESCRIPTION
1	2	Contact PLS	ACC Extension End Plate
2	2	Contact PLS	ACC Extension Handrail Stop
3	Varies	Contact PLS	Handrail H9418 Tape 40mm x 18.3m Black
4	8	FASB/9611	96 x 8 Socket Large Flange Head Set A2
5	Varies	Contact PLS	Shim Yellow Clearing Roll 18.3m
6	7	ACC11B1625-640	Beck Clearing 75 x 64mm
7	1	Contact PLS	Plco Extension Aly

Note:- Filings may vary

25 Extension Pipe and Hoses

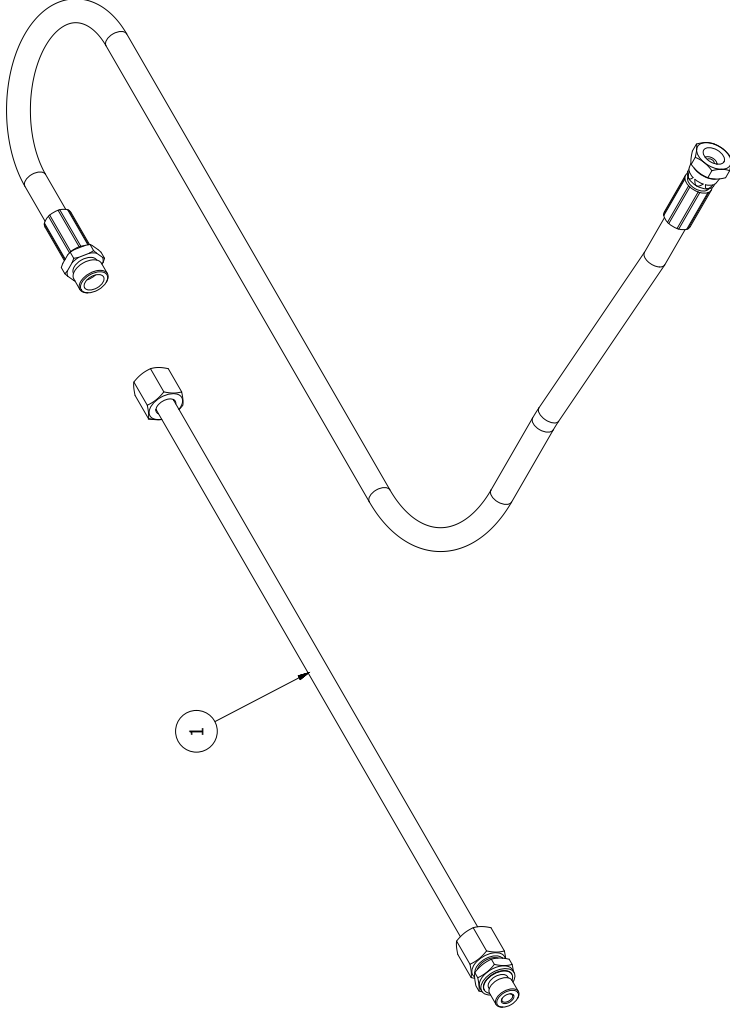

PARTS LIST			
ITEM	QTY	PART NUMBER	DESCRIPTION
1	1	Contact PLS	10 x 1.5 x 395mm Extension Tube & Hose

Note:- Fixings may vary

Roll-Off-Ramp

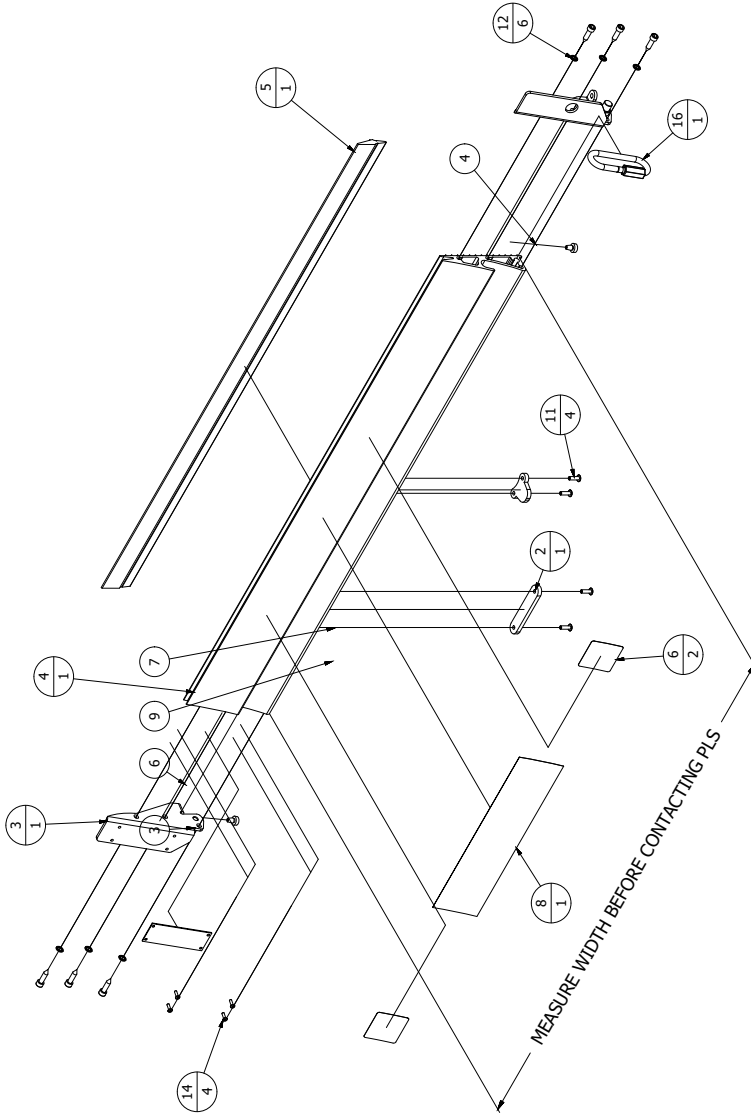

PARTS LIST		DESCRIPTION	
ITEM	QTY	PART NUMBER	
1	1	ACCFABROR0654	ACC Piston Plate
2	1	ACCFABROR0655	ACC Dummy Plate
3	1	ACCFABROR0656-LH	ACC Roll Off Ramp Hinge Plate LH
4	1	Contact PLS	ACC Extruded Ramp 2015
5	1	Contact PLS	ACC Extruded Ramp 2015 Rubber
6	2	ACCPRESREFREDTAPR-R	RED REFLECTIVE PRISMATIC TAPE 50 x 50 x 50m
7	2	CONEC/0001	Handrail Rubber Stop
8	1	LABEL-0008 D1	MEGA Ramp Sticker

9	0.005 l	ADTHR/0001	A1042 Threadlock Adhesive PermaBond 50ml
10	6	FASCC/9001	6.3 x 25mm A2 Socket Cap Head Self Tapper (per 100)
11	4	FASRV/0001	4.8 x 16 Dome Head Rivet
12	6	FASWA/0603	M6 Internal Star Washer
13	1	ACC27521	400 SWL Plate 35 x 95
14	4	FASRV/0013	3.2 x 12 Domed Head Rivet Aluminum
15	1	MEGFABROR120801	MEG Roll Off Ramp Hinge Plate
16	1	ACCLOKUS590-35	Karabiner 90 x 35

Note:- Fixings may vary

27 External Enclosed Pack, Horizontal Position

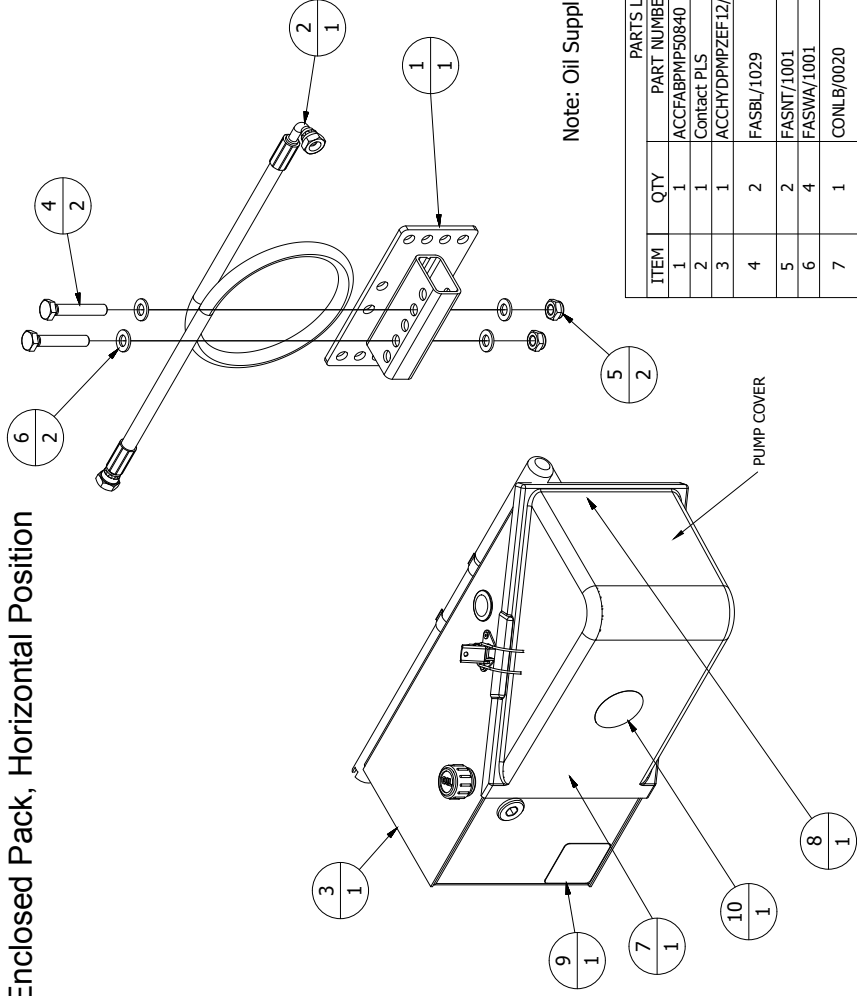

Note: Oil Supplied Separately

ITEM	QTY	PART NUMBER	DESCRIPTION
1	1	ACCFABPMP50840	ACC External Pump Bracket
2	1	Contact PLS	ACC Outer Box Hose
3	1	ACCHYDPMPEZF12/24	RFP Enclosed Pack 12V/24V
4	2	FASBL/1029	M10 x 60 Hex Head Set Screw
5	2	FASNT/1001	M10 Nyloc Nut
6	4	FASWA/1001	M10 Plain Washer Form A
7	1	CONLB/0020	AF26 Alu Foil w/on Labels Serial No. (Pack 350)
8	1	CONLB/0002	WL28 LABEL LEGEND TESTED (PACK 350)
9	1	CONLB/0003	This Way Up & PLS Blue Sticker
10	1	ACC26469	Vinyl Round PLS Label

Note:- Fixings may vary

Internal Enclosed Pack, Vertical Position

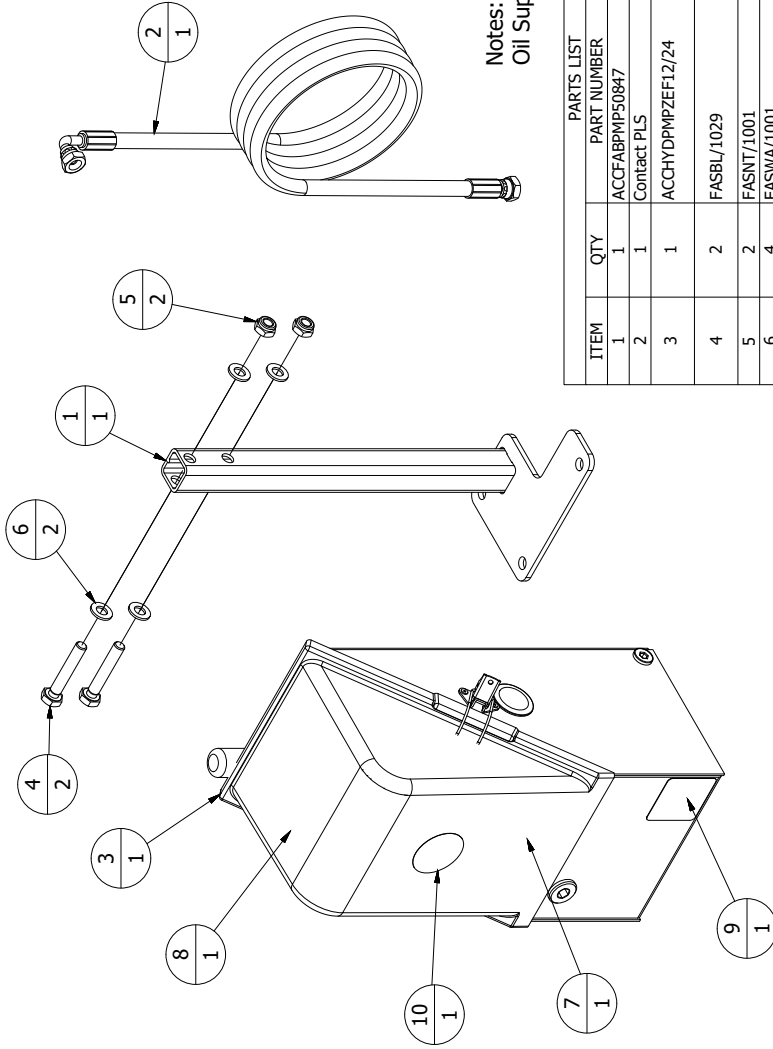

Notes:
Oil Supplied Separately

PARTS LIST			DESCRIPTION
ITEM	QTY	PART NUMBER	
1	1	ACFABPMP50847	ACC Internal Pump Bracket
2	1	Contact PLS	ACC Outer Box Hose
3	1	ACCHYDPMPZEF12/24	RFP Enclosed High Pressure Pack 12V/24V
4	2	FASBL/1029	M10 x 60 Hex Head Set Screw
5	2	FASNT/1001	M10 Nylon Nut
6	4	FASWA/1001	M10 Plain Washer Form A
7	1	CONLB/0020	AF26 Alu Foil w/on Labels Serial No. (Pack 350)
8	1	CONLB/0002	WL28 LABEL LEGEND TESTED (PACK 350)
9	1	CONLB/0003	This Way Up & PLS Blue Sticker
10	1	ACC26469	Vinyl Round PLS Label

Note:- Fixings may vary

29 Handset Kit

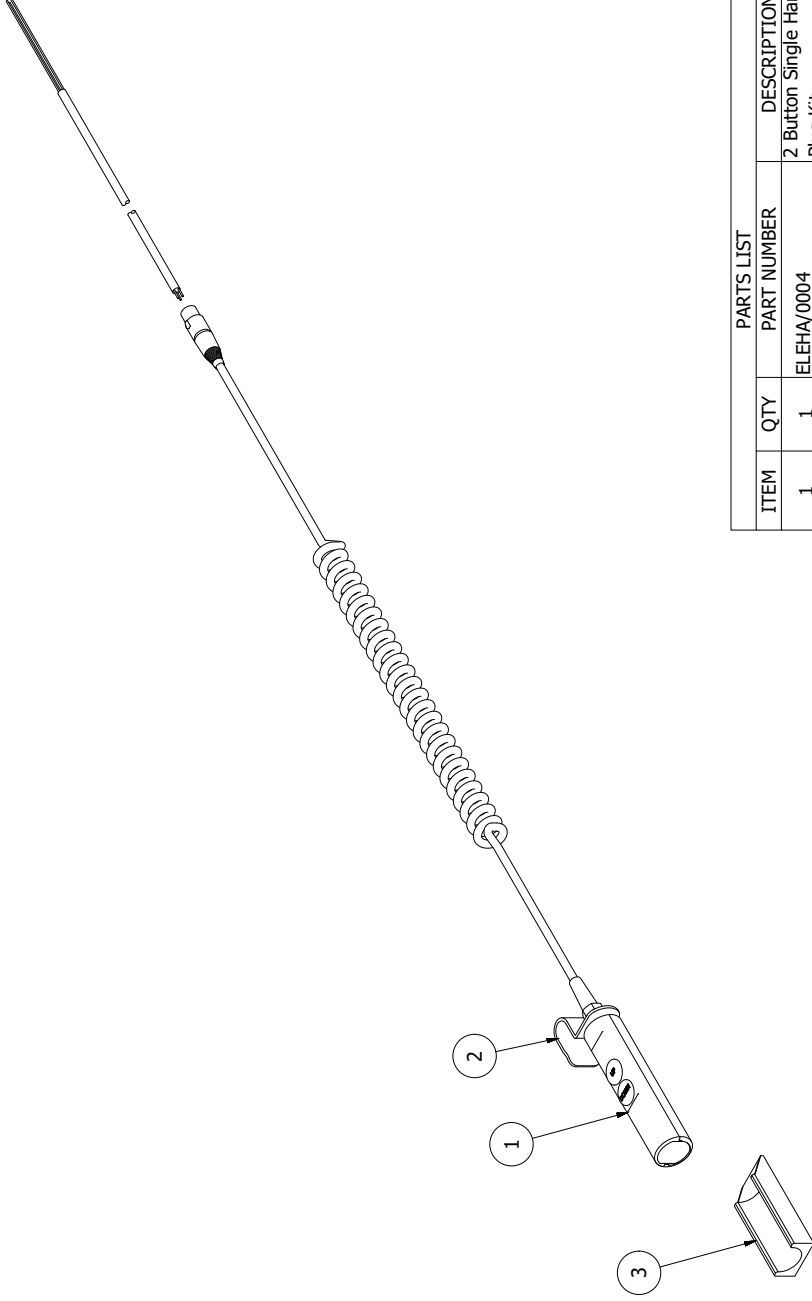

PARTS LIST			
ITEM	QTY	PART NUMBER	DESCRIPTION
1	1	ELEHA/0004	2 Button Single Handset Plug Kit
2	2	ACCALYHAN50735	ACC Standard Handset Hook
3	1	ACC25631	Holster

Note:- Fixings may vary

Moulded Handrail Assembly

Throw "Out" Handrail is **Optional** and **NOT** fitted as standard

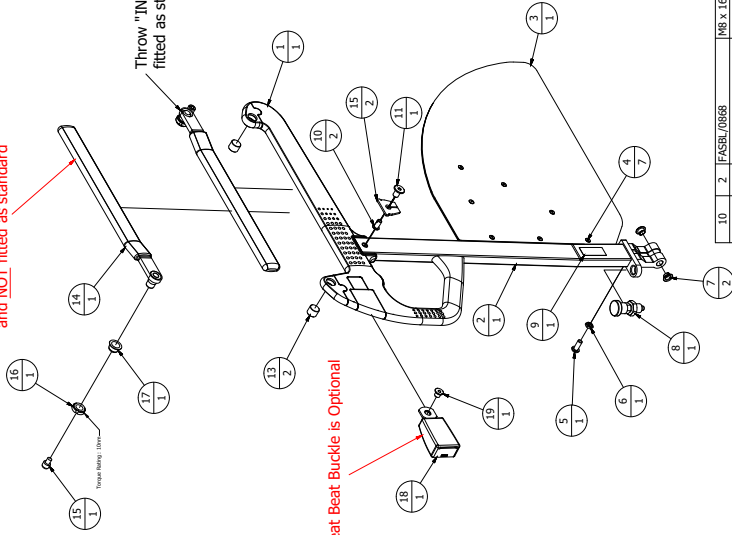

Throw "IN" Handrail is fitted as standard

"WHAN" Seat Beat Buckle is Optional

ASYACCHAN510-0708 LH

ASYACCHAN510-0708 RH

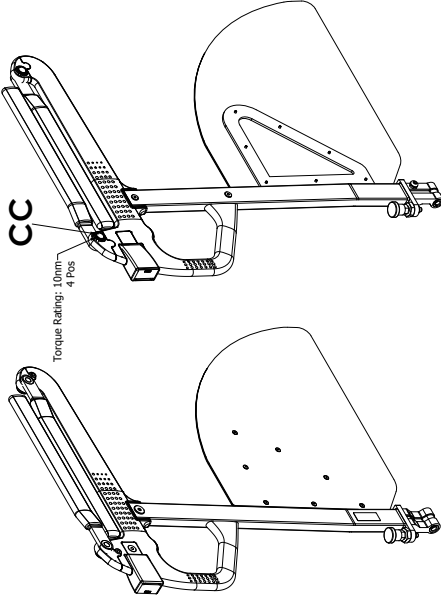

ITEM	QTY	PART NUMBER	DESCRIPTION
10	2	FASBL/0869	M8 x 16 Socket Head Cap Screws Special Low Profile
11	1	FASBL/0820	M8 x 15 Flat Head Socket Interscrew
12	2	ACCP/AHAN50793	MHAN Insert-Hole Plug
13	2	ACCFABHAN50792	ACC MHAN Tube Packer
14	1	ACCFABHAN50789	ACC Modified Handrail Throw
15	1	FASBL/0869	M8 x 10 Socket Head Cap Screw
16	1	FASNT/1502	GIUK Self Locking Nut 13x1
17	1	ACC28672	90mm Beige Buckle
18	1	90BA/DBU/CLE	M8 x 10 Socket Head Cap Screw Special Low Profile
19	1	FASBL/1056	Seat Beat Buckle

ITEM	QTY	PART NUMBER	DESCRIPTION
1	1	ACCFABHAN50788	ACC Modified Handrail
2	1	ACCFABHAN50790-LH	ACC Modified Handrail Leg LH
3	1	ACCP/AHAN50781	ACC Handrail Guard "H"
4	7	FASRL/0808-BLK	3.2 x 10 Large Flange Head Rivet Black
5	1	FASNT/0801	M8 x 20 Socket Head Dome
6	1	FASNT/0802	M8 Half Nut
7	2	FASBL/0803	Flange Gubber Bush 10x12.7
8	1	90BA/DBU/61.5-BK-NI	M8 x 10 Socket Head Cap Screw Special Low Profile
9	1	CONL8/0012	Pin To Umbra Sticker

Note:
Material To Be Removed To Suit Options



Passenger Lift Solutions Limited

Unit 2, Summit Crescent Ind. Est., Off Roebuck Lane, Smethwick,
West Midlands B66 1BT. U.K.

Tel: +44 (0)121 552 0660 Fax: +44 (0)121 552 0200

E-mail: enquiries@pls-access.co.uk

Web Site: www.passengerliftsolutions.co.uk